

10-1-1 Forward

Revised 12/8/2021

Forward

1. This document is issued by Consumers Energy Company as a convenient reference and guide for customers and their architects, engineers, and contractors engaged in the planning, installing or revamping of that portion of the customer's electrical installation which is of mutual concern to the customer and the Company.
2. It is the intent and desire of the Company to render prompt, courteous and satisfactory service to its customers. The Company will endeavor to cooperate with customers, contractors, and others to the fullest extent possible in completing service connections quickly and will give special attention to any particularly difficult situation confronting a customer or their agent.
3. The practices suggested herein are the result of careful investigations and years of experience. Only those installations most frequently encountered are covered in this document. Improved techniques and devices, as well as amendments to, or revisions of, the Company's Electric Rate Schedules and Standard Rules and Regulations may, in the future, require alteration of the practices herein suggested.
4. This document is intended solely as a reference and guide, and the Company does not represent that compliance with its contents will necessarily assure, in all cases, safe installations or completely satisfy all Code requirements. Further, it is not a formal part of the Company's Rules and Regulations; neither is it all-inclusive, nor does it attempt to incorporate all Company policies or outline the conduct of the Company's business.
5. The Company disclaims any responsibility or liability, which may result from work performed in accordance with this document. Except as otherwise specifically stated herein, all work, equipment and materials covered herein shall be furnished, owned, installed and maintained by someone other than the Company, and the Company does not assume any risk, and will not be liable for any claims, demands, rights of action or expense for injuries to persons (including death) or damage to property resulting therefrom.
6. For information concerning the availability and characteristics of electric service and rates, contact the Company.

Electric Meter Operations Standards

10, Customer Information and Requirements

Section 2

10-2-1 Service Area and Offers

Revised 12/8/2021

Service Area and Offices

Territory Served

The Company furnishes electric service in 61 counties in Michigan. The Company's service areas can be viewed at [Consumers Energy Company Service Territory Map](#). General Offices are located at One Energy Plaza, Jackson, Michigan.

Application for service and information concerning the Company's Rules and Regulations relative to providing electric service, characteristics of service available and rates can be obtained by contacting Consumers Energy at phone number 1-800-477-5050.

10-3-1 Definitions

Revised 12/8/2021

Definitions

The following definitions, as they apply to this document, are given for clarity:

1. *Authority Having Jurisdiction (AHJ)* - A person or agency authorized by a government body to inspect and approve customer electrical installations.
2. *Company* - Consumers Energy Company.
3. *Customer* - Person, firm, corporation, association, partnership, municipality, or governmental agency legally using or planning to use electric energy supplied by the Company.
4. *Demand* - The rate at which energy is consumed; that is, the number of kilowatts or kilovolt-amperes consumed during a definite unit of time.
5. *Electrical Code (appropriate)* - The National Electric Code (NEC), Michigan Electrical Code, and Michigan Electrical Code with amendments or other National recognized Electrical Code in effect within the political boundaries where electrical installations are being made.
6. *Generators, Emergency or Standby* - Generators that normally operate only when the Company's electric service is unavailable and are normally connected in such a way that no interconnection can exist.
7. *Meter Socket (trough/base)* - Mounting device for meters. It may be square, rectangular, or the multiunit type. They are rated for continuous operation at 100 percent rated current. Company furnished meter sockets are owned and maintained by Consumers Energy Company.
8. *Mobile Home and/or Modular Home* - Housing mounted on a permanent chassis, termed Mobile homes, either individually or in trailer parks.
 - a. *Recreational Vehicle*: A vehicular unit designed to provide temporary living quarters built on or permanently attached to a self-propelled motor vehicle chassis.
 - b. *Premanufactured Building (Home)* - Any building that is closed construction and is made or assembled in manufacturing facilities on or off the building site for installation, or assembly and installation on the building site.
9. *Pont of Service* - A demarcation point established as the division of ownership between the Company and the customer in the form of a physical connection. Typically the Point of Service is between the Company's supply system and the customer's service facilities. Also referred to as the Pont of Demarcation)
10. *Service Class* - The nature of the service relative to the energy rate.
 - a. *Phases* - Single phase or three phase.
 - b. *Energy Rate* - Residential, Commercial and Industrial. For complete listing, visit our website at : <http://www.consumersenergy.com>.
11. *Service Supply*
 - a. *Overhead Service Drop* - The overhead supply conductors extending from the Company's distribution system to the customer's building or other structure.
 - b. *Underground Service* - The underground supply conductors installed between the point of connection to the company's distribution system and the negotiated point of delivery to the customer.
12. *Service Entrance* - Customer-owned equipment generally consisting of all or part of the following: service head, service riser, service entrance conductors and service entrance equipment.
13. *Service Entrance Conductors* - Conductors installed between the customer's service equipment terminals and the negotiated point of delivery of Company service to the customer.

14. *Service Equipment* – Customer-owned and installed equipment, usually consisting of circuit breakers or a switch and fuses, and their accessories, used both for protection and as a means of disconnecting the supply of energy to the customer's utilization equipment.
15. *Service Head* – A rain-tight fitting for terminating a service entrance cable or raceway containing service entrance conductors at the point where the customer's connections are made to the Company's overhead service.
16. *Service Mast* – A vertical structure installed on low buildings for providing the required clearances and means of support for the Company's overhead service drop.
17. *Splice Box* – A junction box normally installed by the customer/contractor for the purpose of providing a junction between the customer's conductors and the Company's service.

Electric Meter Operations Standards

10, Customer Information and Requirements

Section 4 - General Information

10-4-1 Availability and Classification of Service

Revised 12/8/2021

Availability and Classification of Service

1. Prospective customers shall ascertain from the Company whether or not service is available at a particular location and whether it is overhead or underground before planning an installation or purchasing any major electrical equipment. The company will determine the characteristics of the service available and whether or not any charges are associated with supplying each customer, based on the location of the customer's premises and the nature of the customer's requirements. To make service available, it may be necessary to extend the Company's electrical facilities, which could require an extended period of time for planning and procuring of right-of-way and construction.
 - a. The Company must be informed, therefore, as soon as possible in advance of the customer's requirements and plans. This can avoid unnecessary delay in providing service to the customer and will avoid the possibility of the customer purchasing equipment for which the Company is unable to furnish service. If so requested, the Company will furnish, in writing, information concerning the characteristics of the service available and whether or not payment will be required by the customer.
2. The Company will endeavor to advise and assist its present or prospective customers in the selection or application of electrical utilization equipment and adequate wiring facilities.
3. The information contained in this document refers to service requirements at the usual secondary voltages. Service for installations requiring primary distribution voltages are subject to negotiations between the customer and the Company. Contact the Company at 1-800-477-5050 for assistance.

Electric Meter Operations Standards

10, Customer Information and Requirements

Section 4 – General Information

10-4-2 Application for Service

Revised 12/8/2021

Application for Service

1. Application for initial service or for a change in existing service requirements should be made by calling the Company at 1-800-477-5050. Information needed in order to proceed with the installation can be obtained at that time or found on-line at <https://www.consumersenergy.com>.
2. All applications for service shall show the name of the street or road and house number or other means of identifying the customer's premises.
3. The Company may require a cash deposit by the customer.
4. Any costs determined by the Company for customer requested work, such as new service installations, upgrades, and relocations, are to be paid by the customer prior to the service installation.

Electric Meter Operations Standards

10, Customer Information and Requirements

Section 4 – General Information

10-4-3 Temporary Service

Revised 12/8/2021

Temporary Service

1. The Company offers temporary single-phase or three-phase service for use in construction purposes. The prospective customer should make the necessary arrangement for temporary service directly with the Company.
 - a. When temporary service is supplied from the Company's overhead or underground distribution system, the customer is required to furnish a Company approved support for the attachment of its service conductors and meter, and their service entrance equipment. Facilities to be furnished by the customer, for single-phase service, under this plan are shown on [Figure 2](#) and [Figure 3](#) in Drawings and Wiring Diagrams.

Electric Meter Operations Standards

10, Customer Information and Requirements

Section 4 – General Information

10-4-4 Number of Services and Meters

Revised 12/8/2021

Number of Services and Meters

1. The Company will install one service to a premises. Any exceptions to this rule must be approved by the Company prior to the customer planning an installation or purchasing any major electrical equipment. If an exception is agreed upon by both the Company and the customer, the customer is responsible for all incremental costs and must meet all applicable requirements. Likewise, only one billing meter will be installed for each class of service furnished to each customer in the building.
2. All newly constructed private family (*i.e.* single-family home) and multifamily (*i.e.* apartments) shall have separately metered households. (Electric Rule C4.3(A)(2)).

Electric Meter Operations Standards

10, Customer Information and Requirements

Section 4 – General Information

10-4-5 Alterations and Additions

Revised 12/8/2021

Alterations and Additions

1. In order for the customer to receive adequate service and obtain the proper type of equipment, it is essential that the Company be notified of any changes or additions prior to the customer planning an installation or purchasing any major electrical equipment. The customer will be required to pay any incremental costs associated with altering the existing service.
2. To safeguard their property, the customer is cautioned against installing or permitting the installation of fuses or circuit breakers on any circuit of their wiring system unless such installations meet all applicable requirements. Any means of rendering a protective device inoperative is hazardous to both life and property.

Electric Meter Operations Standards

10, Customer Information and Requirements

Section 4 – General Information

10-4-6 Use of Service by Customers

Revised 12/8/2021

Use of Service By Customers

1. For better service, it is essential that the customer or their contractor make sure that the load is connected and balanced with a minimum of current flow in the neutral wire of 3-wire, 1-phase and 4-wire, 3-phase services.

Electric Meter Operations Standards

10, Customer Information and Requirements

Section 4 - General Information

10-4-7 Substation Metering

Revised 12/8/2021

Telephone Line for Substations

Telecommunications equipment located within substations require high voltage isolation. This specialized equipment is supplied and installed by the local telephone carrier or a qualified contractor. Customers are responsible for the cost of the isolation equipment, if required. If the customer chooses to utilize digital cellular technology instead of high voltage isolation installation, it will be the customer's responsibility to provide a power source to the wireless equipment.

Electric Meter Operations Standards

10, Customer Information and Requirements

Section 4 – General Information

10-4-8 Customer Installed Devices

Revised 12/8/2021

Customer Installed Devices

1. No customer owned devices are to be installed on or within meters and meter sockets, or between the meter and socket.
2. Any customer owned devices found that are not authorized and installed by Consumers Energy will be removed.

Electric Meter Operations Standards

10, Customer Information and Requirements

Section 5 – Connections and Disconnections

10-5-1 Connections and Disconnections

Revised 12/8/2021

Connections and Disconnections

1. All connections or disconnections between the Company's supply system and the customer's service facilities shall be made by the Company or other specifically authorized by the Company in each specific instance to make such connections or disconnections.
2. The Company will not permit unauthorized connections to its facilities. All connections, permanent or temporary, at the Point of Service shall be made by the Company or others specifically authorized by the Company upon notification by the customer and after the Company or others specifically authorized by the Company have determined that all requirements have been met and all applicable inspection releases have been secured. The customer must meet all applicable requirements. .

Electric Meter Operations Standards

10, Customer Information and Requirements

Section 6 – Unauthorized Use of Energy

10-6-1 Tampering

Revised 12/8/2021

Tampering

1. Tampering with the Company's meter is prohibited by Michigan State Law and will not be tolerated by the Company.
2. Tampering with conductors carrying unmetered current is prohibited by Michigan State Law and will not be tolerated by the Company.

Electric Meter Operations Standards

10, Customer Information and Requirements

Section 6 – Unauthorized Use of Energy

10-6-2 Seals

Revised 12/8/2021

Seals

1. Tampering with the Company's meter seals, and the unauthorized breaking of the Company's seals are prohibited by Michigan State Law and will not be tolerated by the Company.
2. If it is necessary in an emergency to destroy a Company seal to gain access to Company equipment, the Company must be notified promptly, and a representative will be sent to inspect and replace the seal.

10-7-1 Inspection

Revised 12/8/2021

Inspection

1. The customer's wiring and equipment shall be installed, upgraded, and maintained in conformance with all applicable requirements. Where inspections are required, they will be made by the Authority Having Jurisdiction (AHJ). The customer is responsible for obtaining all permits and inspections required by applicable law. For their own protection, it is required that customers have their wiring and electric equipment inspected by the Authority Having Jurisdiction (AHJ).
2. At the time of connection, the Company will inspect the customer's metering installation to determine if Company Standards and requirements have been met and that an inspection approval has been given by the Authority Having Jurisdiction (AHJ). Service will be denied for failure to meet Company Standards or to obtain necessary permits and inspection approvals.
3. For reasons of safety to personnel and equipment, the Company will not make a connection between its service and the customer's service unless it can be positively determined that there is no load or no fault on the circuit at the time the connection is to be made. The Company may require access to the customer's service entrance equipment in order to further determine a no load or no fault condition.

Electric Meter Operations Standards

10, Customer Information and Requirements

Section 8 – Service at Distribution Secondary Voltages

10-8-1 General

Revised 12/8/2021

General

1. The Company supplies 60-hertz, alternating current service throughout its service area.
2. The secondary voltage at which service will be provided at a particular location will be determined by the Company.
3. If it becomes necessary for the Company to change the location of the Point of Service for any cause beyond the Company's control, the entire cost of any changes in the customer's wiring made necessary thereby shall be borne by the customer.
4. It is generally mandatory that distribution systems or service connections for any new general service (Commercial and Industrial) or residential subdivisions be placed underground. That determination will be made by the Company.

10-8-2 Overhead Service from Overhead Lines

Revised 12/8/2021

Overhead Service from Overhead Lines

1. Where suitable service is available, the Company will install overhead service connections from its distribution lines to a suitable point of attachment on the customer's premises designated by the Company. The Company will provide the customer with a Service Sketch (Form 2804) which will show the suitable point of attachment on the customer's premises designated by the Company. Where the customer requests a point of attachment other than that specified by the Company, the Company must first agree to a suitable location and the customer must pay any incremental costs prior to the Company proceeding with the design and construction of the request.
2. The height of the service drop attachment to a building or structure will be specified in the Electric Service Location and Service Work Order form furnished by the Company. Refer to Figures in Section 5 and Section 6 in [Drawings and Wiring Diagrams](#). In general, the height for all secondary service attachments should not be less than 12 feet, except for 480-volt, 3-phase delta services, where it should not be less than 15 feet. The following items will be considered by the Company when selecting a service location for the service drop attachment:
 - a. Customer's Structure: Type, height, material; location of windows, doors, porches, eaves, eaves troughs, downspouts, chimneys, and awnings, etc.
 - b. Company's Pole: Location of Company's nearest existing or proposed pole from which the overhead service drop will be extended.
 - c. Clearances: Required clearances over roads, streets, alleys, driveways, sidewalks etc., over communication circuits, from or over structures and equipment.
 - d. Trees: Location of trees and their future growth.
 - e. Suitable location for the Company's service and metering providing the ability for the Company to maintain their facilities.
3. The customer shall furnish a suitable support for the Company's service drop attachment and in no case will the Company be responsible for the damage to any building or structure to which a service drop attachment is made. Refer to [Figure 7](#) Drawings and Wiring Diagrams.
4. Service drop attachments (i.e. house knobs and masts), shall be furnished, owned, installed and maintained by the customer. Metal tubular service masts are also used as a raceway for the service entrance conductors. The Company will specify the minimum size and height of such masts. A typical installation is shown in [Figure 5](#) and [Figure 6](#) in Drawings and Wiring Diagrams.
5. The location for the attachment of the Company's service drop will be so selected that only one attachment (or set of attachments) to the customer's building or structure will normally be required.
6. The Company will furnish and install service wire holders of the type required for attaching to the customer's building. The customer will furnish a suitable anchorage for attaching the service wire holders to all structures. Refer to [Figures 5](#) and [Figure 6](#) in Drawings and Wiring Diagrams. If through-bolts are required, they may be obtained from the Company without cost but will be installed by the customer. Refer to [Figure 7](#) in Drawings and Wiring Diagrams for backing details.
7. Where electric service is desired for a mobile home, basement home, well house, etc., a customer-owned service pole is required to support the service drop, customer's service entrance conductors, service equipment and the Company's meter socket and meter. Refer to [Figure 1](#) in Drawings and Wiring Diagrams.
8. The qualifying farm customers that own and operate the farm and physically occupy the main household which is used as the customer's principal residence and all associated farm buildings/facilities are located on the same premises as the main household, , may in many instances be best served from a point centrally located to the residence and farm buildings in the immediate area. To provide such service in this manner, a Company-owned pole is set at a central location and the customers install their service-entrance conductors on it.

- a. Service to each building is provided by a customer-owned service from the central point location. Contact the Company at 1-800-477-5050 to obtain installation information and metering requirements.
- b. If the customer and the Company agree to installing a Central Point Distribution Pole (refer to [Figures 17](#) and [Figure 18](#) in [Drawings and Wiring Diagrams](#) for typical installations), the customer is required to sign a Central Point Distribution Pole License Agreement prepared by the Company before service entrance conductors and equipment are installed on a Central Point Distribution Pole.

10-8-3 Overhead Service Entrance Conductors

Revised 12/8/2021

Overhead Service Entrance Conductors

1. The service entrance conductors, including a service head, to be connected to an overhead line shall be furnished, installed, and maintained by the customer.
2. These service entrance conductors may consist either of continuous lengths of multiconductor service cable approved for the purpose, individual conductors in electrical conduit or bus duct.
3. The customer should terminate their service entrance conductors at a location and in a manner so that the service head is not less than 6 inches above the highest service drop conductor attachment to the building. The service entrance conductors shall extend at least 2 feet beyond the service head to provide for a drip loop, which will extend at least 6 inches below the service head. Refer to [Figure 4](#), [Figure 5](#), and [Figure 6](#) in Drawings and Wiring Diagrams for a typical installation.
4. The grounded neutral conductor of a single-phase, 3-wire lighting service should be located in the center position of the weather head or service head, with respect to the other two conductors.
5. The power phase conductor of a 4-wire, 3-phase delta (combined light and power) bus duct service entrance should be located above or to the left of the lighting circuit when facing the attachment on the building. For conduit entrances, this conductor should occupy the left or bottom left opening in the weather head. The power phase conductor shall be identified with orange marking at the weather head and in the meter socket (conductor is to correspond with the far right-hand terminal).
6. Raceways enclosing service entrance conductors must be made rain-tight with draining provided.
7. Conduit fittings or boxes with removable covers in the service entrance conduit runs are to be avoided, if possible. In cases where removable covers are necessary for pulling conductors, they should be provided with a locking and/or sealing capability so as to be accessible to Company personnel only.
8. All service entrance conductors, either single or multiconductor, which pass through concealed spaces, shall be installed in a metallic raceway or in approved busways accessible to Company personnel only.
9. Separate sets of service entrance conductors may be installed for each customer in multiple occupancy buildings where there is no common location available for mounting the meters. In such cases, each set of service entrance conductors shall be brought to a common point on the building wall and connected to the single service supplying the building. No unmetered service entrance conductors shall be run through one or more buildings to serve another building unless installed in compliance with the appropriate electrical code in effect.
10. Conductors carrying unmetered energy are not to be located in the same raceway with conductors carrying metered energy.
11. Service entrance conductors shall be sized in conformance with all applicable requirements. It is required by a Public Service Commission rule that the service entrance conductors for residential installations have a minimum current-carrying capacity of 100 amperes. The Company requires that the service entrance conductors for centrally located farm customer installations (refer to [Overhead Service from Overhead Lines](#), item #8) have a minimum carrying capacity of 200 amperes.
12. All final connections at the Point of Service will be made by the Company.

10-8-4 Underground Service

Revised 12/8/2021

Underground Service

1. Where suitable service is available, the Company will install underground service connections from its distribution lines to a suitable point of attachment on the customer's premises designated by the Company. The Company will provide the customer with a Service Sketch (form 2804) which will show the suitable point of attachment on the customer's premises designated by the Company. The supply source may be from a pole in an overhead distribution system, from a padmount transformer or from a secondary (600V and below) junction in an underground distribution system. Where the customer requests a point of attachment other than that specified by the Company, the Company must first agree to a suitable location and the customer must pay any incremental costs prior to the Company proceeding with the design and construction of the request.
2. For residential customers, the Company will own, install and maintain the underground service facilities up to a termination point on the customer's structure designated by the Company, which will normally be the meter socket mounted on the outside wall of the structure. The customer will install the meter socket, and own install and maintain all service conductors and equipment on the load side of this termination point. The customer must request the authorization from the Company to use a pedestal prior to the installation and purchasing of the equipment. If the Company authorizes the use of a pedestal, the customer may install their meter socket on a pedestal that may be constructed using either galvanized steel conduit or treated timber. Refer to [Figure 8](#) through [Figure 12](#), in Drawings and Wiring Diagrams.
3. For commercial or industrial buildings, the Company will own, install and maintain its secondary (600V or below) voltage service facilities up to a negotiated Point of Service on the outside surface of the building wall or the secondary compartment of the padmount transformer. The customer shall own, install and maintain all conductors and equipment on the load side of the Point of Service. For high-rise construction, buildings having three or more floors, the Company shall be consulted regarding all requirements, including metering.
4. For mobile homes in parks with individual services, the Company will own, install and maintain an underground service to its termination in a Company meter socket. The socket will normally be mounted on a supporting structure, referred to as a pedestal. The pedestal is owned, installed and maintained by the mobile home park owner, along with the required service disconnect box. The pedestal and its location must have prior design approval from the Company. The Company will furnish the meter socket and any service conduit to the meter socket when required. Refer to [Figure 14](#), [Figure 15](#), and [Figure 16](#), in Drawings and Wiring Diagrams. Premanufactured pedestals must be preapproved before installing. Refer to the company's "[Customer Purchased Meter Sockets & Equipment Approved List](#)" for a listing of approved metering pedestals.
5. Individual mobile homes, basement homes, well houses, and other structures the Company designates, require a customer owned service pedestal or pole to support the Company's service conductors, customer's service conductors and equipment and the Company's meter. Refer to [Figure 12](#), [Figure 14](#), [Figure 15](#), and [Figure 16](#), in Drawings and Wiring Diagrams.
6. For mobile homes attached to a permanent foundation that are considered a permanent dwelling, a metering pedestal is not required and the meter socket shall be attached to the permanent structure as required by the Company.

Electric Meter Operations Standards

10, Customer Information and Requirements

Section 9

10-9-1 Secondary Lightning Arresters

Revised 12/8/2021

Surge Arresters

Surge arresters shall be owned, installed, and maintained by the customer. They shall be installed within the customer service entrance equipment and meet all applicable code requirements. They shall not be installed in meter sockets, metering equipment or at the Point of Service.

Electric Meter Operations Standards

10, Customer Information and Requirements

Section 10

10-10-1 Transformer Vaults

Revised 12/8/2021

Transformer Vaults

For reasons of convenience, aesthetics, or unusual circumstances, it may be necessary to place transformers in vaults in metropolitan areas, built by the customer on their premises. The customer or their agent should consult the Company for information concerning the necessity, location, and Company requirements for vaults.

10-11-1 Code & Standards Compliance

Revised 12/8/2021

Code & Standards Compliance

1. Consumers Energy Adheres to the National Electric Safety Code (NESC) and supports the National Electric Code (NEC) for the practical safeguarding of persons and property. Safety to the public, the customer and Consumers Energy employees is of utmost concern.
2. The NESC applies to Consumers Energy's facilities and equipment up to the Point of Service, including meter sockets and metering equipment. The NEC applies to the customer's service entrance equipment.
3. Consumers Energy has established Standards for safe, uniform, practical and economical billing metering installations throughout the Company's service area. These Standards shall be used for all new or rebuilt metering installations and must be adhered to.
4. Customer's service entrance equipment (including meter sockets and metering equipment) must be installed in accordance with Consumers Energy's Standards as well as the National Electric Code and any other local codes enforced by the Authority Having Jurisdiction. Consumers Energy reserves the right to refuse service to a metering installation that does not meet these requirements.
5. Proper grounding and bonding of meter sockets and metering equipment is to be completed with no grounding or bonding conductors exiting directly out of meter sockets or metering equipment. Do not route grounding conductor (from disconnect to ground rod) through the meter socket or associated equipment. The meter socket or metering equipment is not to be used for a junction box or a raceway for customer's wiring. No external devices are to be attached directly onto the meter socket or metering equipment for Intersystem Bonding Terminations (IBT).

Electric Meter Operations Standards

10, Customer Information and Requirements

Section 12 – Meter Installation at Distribution Secondary Voltages 600 Volts and Below

10-12-1 Meter Installation at Distribution Secondary Voltages 600 Volts and Below

Revised 12/8/2021

Meter Installation at Distribution Secondary Voltages 600 Volts and Below

Metering Equipment

1. Metering equipment furnished, owned and maintained by the Company includes: meters, one and two position self-contained meter sockets, instrument transformers, instrument transformer rated sockets, instrument transformer rated enclosures and other related metering auxiliaries. For metering installations that require a three or more position self-contained meter socket, the customer will be required to purchase approved meter sockets from a distributor or supplier of their choice. Maintenance of meter sockets and metering equipment purchased by the customer will be the responsibility of the customer. Refer to the company's ["Customer Purchased Meter Sockets & Equipment"](#) reference guide for a complete listing of approved meter sockets and metering equipment.
2. The term "socket" refers to the mounting devices for all meters and may be of the rectangular or multiunit trough type. These sockets are made for use on both single-phase and three-phase installations and are available for self-contained meters with ratings up to 400 amperes intermittent duty, 320 amperes continuous duty.

Electric Meter Operations Standards 10, Customer Information and Requirements

Section 12 – Meter Installation at Distribution Secondary Voltages 600 Volts and Below

10-12-2 Meter Location

Revised 12/8/2021

Meter Location

1. Each customer will be required to provide, without cost to the Company, a mounting space on the exterior of the building which is acceptable to the Company for the installation of the necessary metering equipment. After an installation has been completed, the subsequent changes in the location or type of meters for the convenience of the customer will be made at the customer's expense. The Company shall be consulted before making any alterations requiring a change in the meter location.
2. The Company requires that the metering equipment, unless impractical, be located outdoors. Meters in existing indoor installations that are to be arranged so as to affect the service entrance conductors or service equipment shall be changed to an outdoor location. In those cases where there is no suitable outdoor location, indoor locations must be preapproved by the Electric Meter Operations department, and must be as near as practicable to the point where the service entrance conductors enter the building, have direct outside access, and the room shall be used for electrical equipment only. Interior walls, panels or meter boards on which meters are mounted shall be rigid and free from vibration and shall be located in a clean and dry part of the building.
3. Meters are not to be mounted on customer's switchboards, cubicles, or metal frames without obtaining the Company's approval.
4. When metering equipment is to be installed in customer-owned switchgear or automatic transfer switchgear, the arrangement of the equipment must be approved by the Company's Electric Meter Operations department prior to installation. Technical information such as manufactures' drawings and specifications, site plan drawings, etc., may be required for the approval process. Consumers Energy's Electric Meter Operations department will provide any necessary information such as the mounting and space requirements to the customer, who is responsible for compliance to the Company's standards.
5. All meters and auxiliary equipment shall be located to be readily accessible and without restriction to the Company's authorized personnel for such purposes as: reading, testing, maintenance, service termination and restoration.
6. The height of the meter center lines above ground or floor level shall be as follows:
 - a. 5'-0" maximum to 3'-6" minimum (5'-0" preferred) for all self-contained, single-phase and three phase meters for single position sockets, multi-position horizontal style sockets, and all instrument transformer rated sockets.
 - b. 5'-6" maximum to 2'-6" minimum for all self-contained, single phase and three-phase meters for "Modular" vertical style meter sockets and single phase "Meter Pak" vertical style sockets.
7. Meters shall not be mounted where they will be subjected to damage. Such as extended unguarded into narrow alleys or driveways, nor under eaves where they will be subjected to excessive water and the formation of ice. Where meters are exposed to an undesirable environment, the customer shall provide adequate protection in the form of railings, guards, or complete enclosures.
8. Meters should not be installed in locations where Company employees could inadvertently damage the customer's property, such as flower beds or shrubbery. Nor should they be located in areas where it will be necessary for them to climb over or under obstacles and obstructions, such as fences or decks to read or service the installation or otherwise cause inconvenience to either the customer or the Company's representative.
9. Electrical metering equipment shall not be located adjacent to gas pipes or closer than three feet to a gas meter.

10-12-3 Metering Equipment Installation - General

Revised 12/8/2021

Metering Equipment Installation - General

1. The customer shall install only metering equipment either furnished to them by the Company or customer purchased metering equipment that is approved by Consumers Energy. The customer shall furnish, install, own and maintain all customer-owned service equipment, all wiring and conduits.
2. The customer or their contractor shall make arrangements with the Company for the proper meter sockets, instrument transformer enclosures (cabinets) or any other metering equipment required for this particular installation.
3. Meter sockets and metering equipment issued by Consumers Energy will be determined by the Company according to the customer's service entrance load conductor size and ampacity rating.
4. Metering equipment installed on wood-frame buildings or structures should be securely fastened with nonferrous screws. The siding should be reinforced with additional backing in those cases where it is not possible to set the screws into the studding. Refer to [Figure 22](#) in Drawings and Wiring Diagrams. Expansion shields or lead anchors equipped with galvanized machine screws should be used for installing metering equipment on masonry walls. Refer to [Figure 22](#) in Drawings and Wiring Diagrams.
5. Meter sockets shall be rigidly mounted with socket jaws vertical and plumb so that the meter will be in a true vertical position when installed in the socket.
6. Sockets shall be surfaced mounted and are not to be concealed or embedded in building walls.
7. When back knockouts in sockets are used, the contractor/customer shall install conductors and/or conduits in such a manner as to prevent damage to both the meter equipment and customer's structure (i.e., seepage due to rain, snow, ice, etc.).
8. Meter sockets, meter junction (connection) boxes, and instrument transformer enclosures shall not be used as splice boxes or raceways and no wiring other than service entrance and bonding conductors shall be run through this equipment. Consumers Energy's underground service conductors normally enter on the bottom, left-hand side of sockets and enclosures. Customer's conductors should not be located within this area, to ensure that the conductors do not cross or touch. The customer's service conductors should normally exit through the bottom right-hand side or the lower right-hand side of the sockets and enclosures. Customer's service conductors may exit the back of the meter socket where there is proper wiring bending space. With horizontal style multi-position sockets, the conductors shall exit through the bottom of the sockets. Any exceptions require the approval of the Company's Electric Meter Operations department.
9. Interior meter boards of adequate size for the meter installation shall be furnished by the customer to provide a smooth and dry surface for mounting the metering equipment in those cases where the customer's walls or structure are not suitable for direct mounting.
 - a. Interior meter boards are to be constructed of 3/4"-inch plywood or other approved material, painted on both sides with good quality paint and mounted rigidly on the wall or structure in a true vertical position.
 - b. The location and size of the meter board shall be such as to allow at least a 12-inch clear space above the meters, and all vertical conduit runs to and from the service equipment shall be kept at least eight inches from the sides of all meter troughs to facilitate the installation and testing of the meters.
10. Customer wire terminations within meter sockets and metering equipment shall be installed into the proper connectors (lugs) provided or specified by the Company. Mechanical stud type connectors (lugs) are to be installed surface-to-surface onto bus bars with no objects in between such as washers or oxide inhibitor compounds.
11. Where the mobile home park distribution system is underground and owned by the Company, the customer shall furnish and install a Company-approved metering pedestal with grounding connections at each mobile home. The Company will furnish the meter socket that is to be installed on the approved pedestal that shall be constructed according to Company standards.

Electric Meter Operations Standards 10, Customer Information and Requirements

Section 12 – Meter Installation at Distribution Secondary Voltages 600 Volts and Below

10-12-4 Metering Equipment Installation – Single-Phase Meter for Loads up to 400 Amperes

Revised 12/8/2021

Metering Equipment Installation – Single-Phase Meter for Loads up to 400 Amperes

1. *Single Meter Installations* – For single-phase 120/240V services up to and including 400 ampere intermittent duty (320 ampere continuous duty), the Company will furnish self-contained, single position meter sockets to be installed by the customer. The type of socket furnished will depend upon the size of the customer's service entrance conductors. Refer to [Figure 23](#) through [Figure 27](#) in Drawings and Wiring Diagrams for a physical arrangement of the following sockets:
 - a. *Overhead Services* – For overhead installations, the Company furnishes the meter socket. A specified meter socket will be furnished for services up to 100 amperes and will accommodate conductor sizes up to 1/0 AWG copper or equivalent. A specified meter socket will be furnished for 200 amp services to accommodate conductor sizes up to 250 kcmil. A specified meter socket will be furnished for 400 amp services to accommodate conductor sizes up to 500 kcmil or parallel conductor sizes up to 250 kcmil. Services over 400 amperes and any single phase 480 volt service will require Instrument Transformer Rated metering equipment.
 - b. *Underground Services* – For underground installations, the Company furnishes the meter socket, line conduit and fittings. A specified meter socket will be furnished for services up to 200 amperes and will accommodate conductor sizes up to 350 kcmil. A specified meter socket will be furnished for 400 amp services to accommodate conductor sizes up to 600 kcmil or parallel conductor sizes up to 250 kcmil. Services over 400 amperes and any single phase 480 volt service will require Instrument Transformer Rated metering equipment.
2. *Grouped Meter Installations* – Meters and customer's service equipment for two or more customers occupying apartments or offices in the same building are to be grouped in one location.
 - a. Because of the various types of sockets available for this type of installation, the customer shall always consult with the Company when planning grouped meter installations. Only Company approved metering equipment is to be installed.
 - b. For grouped installations of six meters or less, the meter sockets shall be installed in the service entrance conductors ahead of all the customer's service equipment. For grouped installations of more than six meters, a main service switch is required in the service entrance conductors ahead of the meters. Refer to [Figure 27](#), [Figure 32](#), and [Figure 33](#) in Section 15 for typical physical arrangements drawings and wiring diagrams.
 - c. Each customer's equipment in a grouped installation shall be plainly and permanently identified by apartment number, suite number, building number, portion of building, etc., by the contractor, at the time the installation is made, to indicate the portion of the building served by each customer's service equipment. Refer to [Figure 32](#) in Drawings and Wiring Diagrams. Incorrect marking by the customer which results in incorrect billing, will be corrected at the customer's expense.

Electric Meter Operations Standards

10, Customer Information and Requirements

Section 12 – Meter Installation at Distribution Secondary Voltages 600 Volts and Below

10-12-5 Metering Equipment Installation – Three-Phase, Services of 400-Ampere Capacity or Less, 120 to 480 Volts

Revised 12/8/2021

Metering Equipment Installation – Three-Phase, Services of 400-Ampere Capacity or Less, 120 to 480 Volts

1. The Company will furnish the appropriate three-phase one or two position meter socket, suited to the type of service required by the customer, to be installed by the customer. Refer to [Figure 28](#) through [Figure 31](#) in Drawings and Wiring Diagrams for typical physical arrangement drawings and wiring diagrams.
2. Grouped installations of polyphase meters requiring a three or more position three-phase, self-contained meter socket, are special situations that generally require special installation methods. Therefore, the customer must consult with the Company for a list of [“Customer Purchased Meter Sockets & Metering Equipment”](#) when planning and designing this type of installation. Refer to Figure 33 in Drawings and Wiring Diagrams.

Electric Meter Operations Standards 10, Customer Information and Requirements

Section 12 – Meter Installation at Distribution Secondary Voltages 600 Volts and Below

10-12-6 Metering Equipment Installation – Single-Phase or Three-Phase Service Over 400 Amperes

Revised 12/8/2021

Metering Equipment Installation – Single-Phase or Three-Phase Services Over 400 Amperes

1. Instrument Transformer Rated metering will be installed on services over 400 amperes and all 480 volt three phase delta and 480 volt single phase services. Current transformers are required in installations where the customer's load may exceed 400 amperes and voltage transformers are necessary where the service voltage does not provide 120 volts. Instrument Transformer Rated installations must be coordinated with the local Electric Meter Operations department.
2. For indoor instrument transformer enclosures, the Company will furnish to the customer its standard instrument transformer (CT) cabinet with brackets for mounting the instrument transformers. These cabinets house only the transformers and their mounting brackets and instrument transformer secondary connections to the meters. Only the service entrance conductors and the bonding conductor shall enter, exit or be terminated into the transformer cabinet. Parallel service entrance conductors in one or more conduits are permitted. The Company will not permit any branch circuit taps to be made in the cabinet. The customer will provide information on suitable enclosures for installations having special non-standard requirements. Such enclosures must be pre-approved by Consumers Energy's Electric Meter Operations department prior to installation. For installation configuration and minimum/maximum mount heights, refer to [Figure 34](#) and [Figure 35](#) in Drawings and Wiring Diagrams for typical installation drawings.
3. For outdoor instrument transformer enclosures, the Company will furnish either its standard CT cabinet described above in Item 2, or a Transocket. In some cases, a smaller enclosure which will house window-type current transformers may be mounted at or near the secondary overhead service entrance point of attachment. These smaller enclosures shall not be installed above 16 feet from ground level unless special permission is granted by the Company. Refer to [Figure 36](#) in Drawings and Wiring Diagrams.
4. The Company will furnish meter sockets, complete with metering test switches, for the mounting of instrument transformer rated meters. The space provided by the customer for the location of the metering equipment should be adequate for any anticipated future demand metering or other additions. When the meters are installed above, below or to the side of the instrument transformer cabinet, it is necessary that a 24" x 24" space be reserved for this purpose and meet all mounting height requirements.
5. All metering transformer cabinets, boxes, sockets, and metering conduit runs shall be installed by the customer. Likewise, all service entrance wiring will be completed by the customer and no open or exposed wiring in the service, or metering and service equipment, will be permitted in this type of installation. The wiring from the instrument transformer secondaries to the meter and accessories will be installed by the Company at the time the meter is set. If it is necessary to locate the meter remote from the instrument transformer cabinet, the distance between the two shall not exceed 100 feet without prior approval from the Electric Meter Operations department.
6. When instrument transformer rated metering, 600 volts or less, is required, the preferred metering method will be to meter at the padmount transformer when underground. The Company will determine the type and location of the metering equipment. The customer will be required to run service conductors to the secondary compartment of the padmount transformer. The Company makes all final terminations. For overhead installations, contact the local Electric Meter Operations department.
7. If the Company decides to padmount meter a customer and the customer requests the Point of Service on their building wall, the customer is responsible for all incremental costs; trench charge for underground service and a junction cabinet for Company and customer service terminations. The metering will remain at the Company's padmount transformer location.

8. Where the instrument transformers and/or service entrance conductors are of such a size that it is not practical to use the instrument transformer cabinets furnished by the Company, the transformers may be mounted in the customer's bus structure, provided they are adequately protected and readily accessible to authorized Company representatives for inspection and testing. However, before such an installation is made, the Company must be consulted regarding the metering equipment location and facilities required.
9. In those installations where the metering transformers are to be mounted in factory-assembled switchgear owned by the customer, manufacturer's drawings of the proposed installations must be submitted to Consumers Energy's Electric Meter Operations department for approval prior to installation.

10-13-1 Service and Meter Installations at Distribution Primary Voltages

Revised 12/8/2021

Service and Meter Installations at Distribution Primary Voltages

1. Service at primary voltages is subject to special negotiations between the customer and the Company, since the meter and service installations require special engineering and metering consideration. The Company shall be consulted well in advance of the time such service will be required so that the customer's and the Company's design and construction work may be properly coordinated, and so that the Company-furnished equipment will be available. Generally, the Point of Service will be at the customer's property line and the customer will be responsible for the equipment and cables beyond that point.
2. When the customer intends to install a three-phase power transformer, the Company shall be contacted for recommendations.
3. Primary metering cubicles included in the switchgear may be preferred by the customer for reasons of convenience, aesthetics, or economy. In those instances, the customer will furnish the metering cubicle, conforming to Company specifications, for the Company's metering equipment. Contact the Electric Meter Operations department to obtain information on these specifications.
4. The customer shall provide, free of expense to the Company and at the Point of Service, suitable space for the installation of the necessary metering equipment.
5. A customer owned controlling device is required to be installed at a location mutually acceptable to the Company and the customer, which is normally at the property line. This controlling device shall meet the NEC and local codes, provide a visual air clearance, have the ability to be operated by non-utility personnel, have a fault-closing rating not less than the maximum short-circuit current available at its supply terminals, and simultaneously disconnect all phase (ungrounded) conductors.
6. The Company may elect to meter the primary customers load in their distribution padmount transformer instead of constructing primary metering. The Point of Service remains where the Company's primary conductors terminate on the customers primary conductors. This method of metering is limited to primary customers that will require no more than two secondary voltage metering installations.

Electric Meter Operations Standards

10, Customer Information and Requirements

Section 14 – Service Equipment

10-14-1 Location

Revised 12/8/2021

Location

1. The customer's secondary voltage service equipment shall always be located in a readily accessible place, as close as practicable to the point where the service entrance conductors enter a building. The location selected shall be one not likely to become obstructed so as to cause inconvenience to the customer when it becomes necessary to operate the equipment or to renew fuses. A clear space in front of such equipment shall be provided in accordance with all applicable code requirements; not less than four feet is recommended.
2. The service equipment must be readily accessible and shall not be located in areas where the only entrance is through a trapdoor, by ladder, or in any location difficult to enter in an emergency, nor in wet, dirty or cramped areas.
3. The customer's outdoor service equipment shall be rain tight.
4. Consideration should be given to locating the branch circuit protection devices on the same floor with the branch circuits. The use of such sub distribution centers, fed by suitable feeder circuits, will result in shorter branch circuits and greatly improved voltage conditions.

Electric Meter Operations Standards

10, Customer Information and Requirements

Section 14 – Service Equipment

10-14-2 Interrupting Capacity of Protective Devices

Revised 12/8/2021

Interrupting Capacity of Protective Devices

1. Overcurrent protective equipment installed on customer's systems must have the interrupting ability for handling short circuit currents that will flow when a fault occurs on the customer's distribution system. The circuit breakers or fuses selected must operate to isolate such faults without damage to the circuit conductors or equipment and with a minimum shutdown time. Upon request, the Company will furnish short circuit current values that are based on calculations and information currently available to the Company which is based on the current circuit configuration and equipment that has not been field verified and is subject to change without notice. The Company does not guarantee that the customer's service equipment will continue to be adequate for handling any increase in the short-circuit current that may be available due to system changes.

Electric Meter Operations Standards

10, Customer Information and Requirements

Section 14 – Service Equipment

10-14-3 Service Equipment, Single-Phase

Revised 12/8/2021

Service Equipment, Single-Phase

1. The customer's service equipment shall meet all applicable requirements and irrespective of type, should be adequate to fully utilize the capacity of the service entrance conductors. For residential installations, this service equipment shall have a rating of not less than 100 amperes at three-wire, single-phase, 120/240 volts.

Electric Meter Operations Standards

10, Customer Information and Requirements

Section 14 – Service Equipment

10-14-4 Service Equipment, Polyphase

Revised 12/8/2021

Service Equipment, Polyphase

1. The main service disconnecting means for polyphase services are required to be the sealable type when they are installed on the “line” side of the metering equipment. Otherwise, they can be the same, or similar, to the general type used for single-phase service.

Electric Meter Operations Standards

10, Customer Information and Requirements

Section 14 – Service Equipment

10-14-5 Special Service Equipment

Revised 12/8/2021

Special Service Equipment – Generators and Generation

Standby Generators

Customers having secondary voltage standby generating equipment must meet the following criteria.

1. Customer's wiring and equipment must meet all local and state regulatory requirements.
2. All required permits must be obtained (i.e. county, township, city, etc.)
3. The system must pass the electrical inspection.
4. The generator must be electrically isolate from Consumers Energy's system by either:
 - a. A transfer switch or similarly approved isolation switch, which must be installed to isolate the generator from Consumers Energy's system. Customers must purchase these from distributors. A list of approved model numbers of combination meter socket/transfer switch is located on the Company's website under ["Customer Purchased Meter Sockets & Metering Equipment"](#)
 - b. Or when equipment and/or appliances are directly connected to the generator using flexible extension cords with current ratings adequate for the equipment and/or appliances being served.
5. Refer to [Figure 38](#), [Figure 39](#), and [Figure 40](#), in Drawings and Wiring Diagrams.

Parallel Generation

The Company will allow parallel operation of a customer's generation facilities if those facilities meet Company requirements. Customers desiring to operate solar, biomass, wind-powered or other types of generators in parallel with the Company's system will be required to enter into a written agreement covering the installation and operation of customer's generator system.

An individualized study is required for each site, or whenever additional generation is added at an existing site. Customers proposing to interconnect generation must pay an application fee and provide data related to the generator(s). An additional fee may later be required for a study. Generators that can feed power back into the Company's system require a more complicated study than generators that just offset a portion of the customer's usage or are used as an emergency backup during utility outages.

See Consumers Energy's website, [Generator Interconnection Information](#) for more details.

Electric Meter Operations Standards

10, Customer Information and Requirements

Section 14 – Service Equipment

10-14-6 Power Factor

Revised 12/8/2021

Power Factor

1. It is desirable for the customer to maintain their power factor near unity because of the economies resulting therefrom. A power factor near unity will improve voltage regulation, facilitate the delivery of the rated voltage to the utilization equipment and decrease losses. Consult the Company for specific information.

Electric Meter Operations Standards

10, Customer Information and Requirements

Section 14 – Service Equipment

10-14-7 Residential High-Rise and Apartment Buildings

Revised 12/8/2021

Residential High-Rise and Apartment Buildings

1. For high-rise construction, buildings having three or more floors, the Company shall be consulted regarding all requirements, including metering.
2. The customer shall furnish modular grouped meter installations with individual breakers for residential high-rise and apartment buildings.
3. Only Company approved metering equipment is to be installed.
4. Refer to the Company's [“Customer Purchased Meter Sockets & Equipment”](#) reference guide for a listing of approved meter sockets and metering equipment. Refer to [Figure 32](#) and [Figure 33](#) in Drawings and Wiring Diagrams.
5. Refer to [Grouped Meter Installations #2 \(c\)](#) for further requirements.

Electric Meter Operations Standards

10, Customer Information and Requirements

Section 15

10-15-1 Drawings and Wiring Diagrams

Revised 12/8/2021

Drawings and Wiring Diagrams

Mobile Home Overhead Service Customer Pole

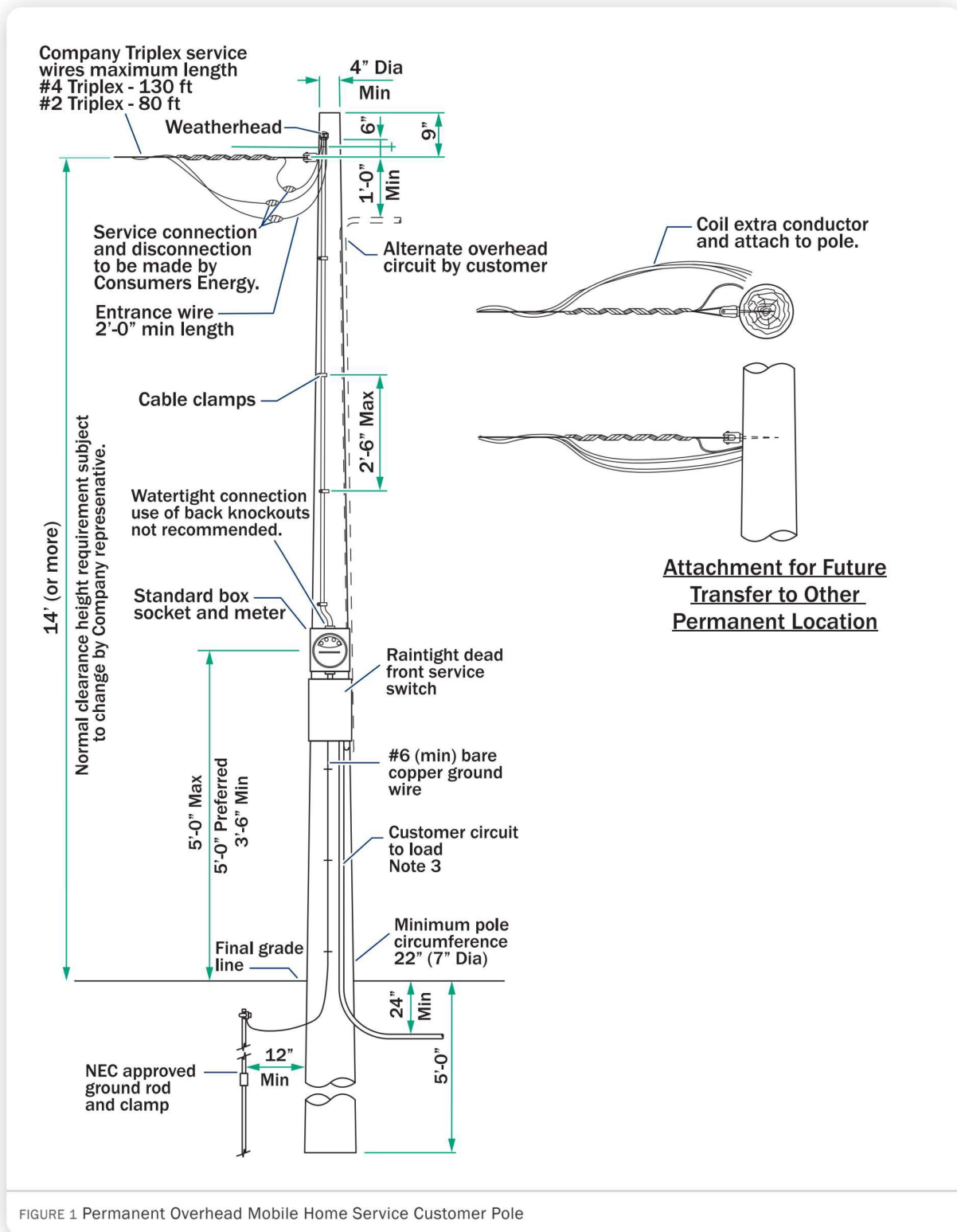

FIGURE 1 Permanent Overhead Mobile Home Service Customer Pole

Notes

1. The customer must furnish and install the service support and all service wiring and equipment in a location mutually acceptable to both the customer and the Company.
2. Service support must have a minimum length of 20' with a setting depth of 5' and full length treatment of a commercially applied preservative. Approved supports are:
 - a. Preferred - a utility or construction type cedar or pine pole
 - b. Alternate 1 - A 6" x 8" construction timber set with narrow side facing the Source Or the service

- c. Alternate 2 - A 6" x 6" timber limited to 1 15' maximum span length and reduced service tension of No 4 Triplex shown below
- 3. The customer must install wiring and equipment in accordance with local or National Electrical Codes. The customer must not mount the service entrance meter socket or disconnect equipment directly on a mobile home.
- 4. The Company will connect the service and set the meter when the installation is completed and inspected or released by the electrical inspector.

Special Increased Stringing Sags to 6" x 6" Treated Solid Timber for #4 Triplex (400 lb Maximum Tension)				
Span Length	50'	75'	95'	115' (Maximum)
Stringing Sags 60° F	1'-0"	2'-3"	3'-4"	4'-8"
TABLE 1				

Temporary Overhead Service Customer Pole

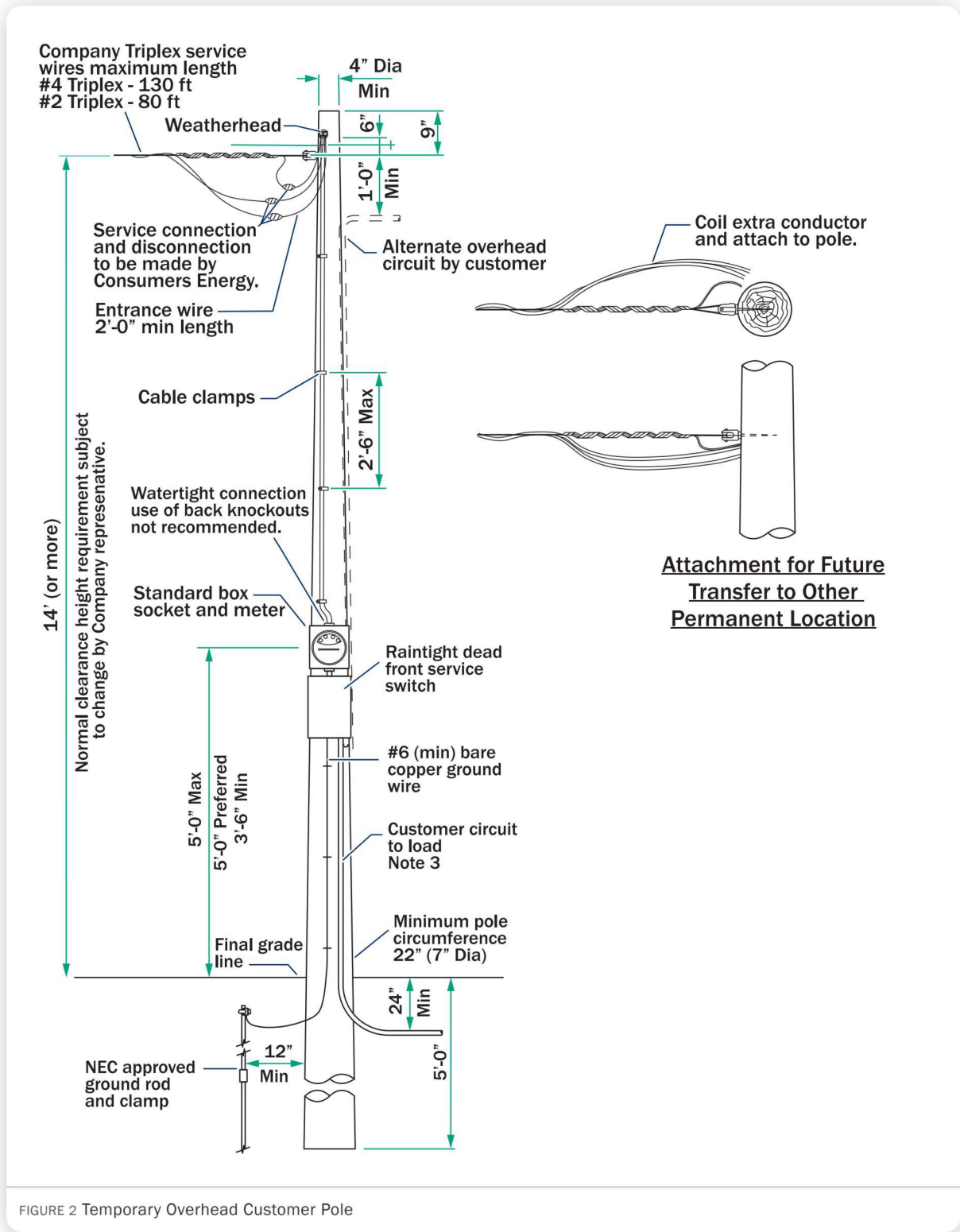

FIGURE 2 Temporary Overhead Customer Pole

Notes

1. The customer must furnish and install the service support and all service wiring and equipment in a location mutually acceptable to both the customer and the Company. The customer is responsible for installing and maintaining all the equipment beyond the point of service i.e. the meter base, including the conductor from the load side of the meter to the load.
2. The service support must have a minimum length of 20' with a setting depth of 5' and a full-length treatment of a commercially applied preservative. Approved supports are:

a. Preferred—a utility or construction type cedar or pine pole

Printed on: 04/07/2022 | This version is only valid if the revision date matches the online version.

- b. Alternate 1—a 6" × 8" construction timber set with the narrow side facing the source or the service
 - c. Alternate 2—a 6" × 6" timber limited to 115' maximum span length and a reduced service tension.
3. The installation, including the service equipment, must comply with the National Electrical Code (NEC) as indicated by the Michigan Electrical Code (MEC) and approved by the Authority Having Jurisdiction (AHJ) (i.e. the electrical inspector).
 4. The Company will connect the service and set the meter when the installation is completed and inspected or released by the electrical inspector.
 5. The customer must not mount the service entrance meter socket or disconnect equipment directly on a mobile home.

Temporary Underground Service Support

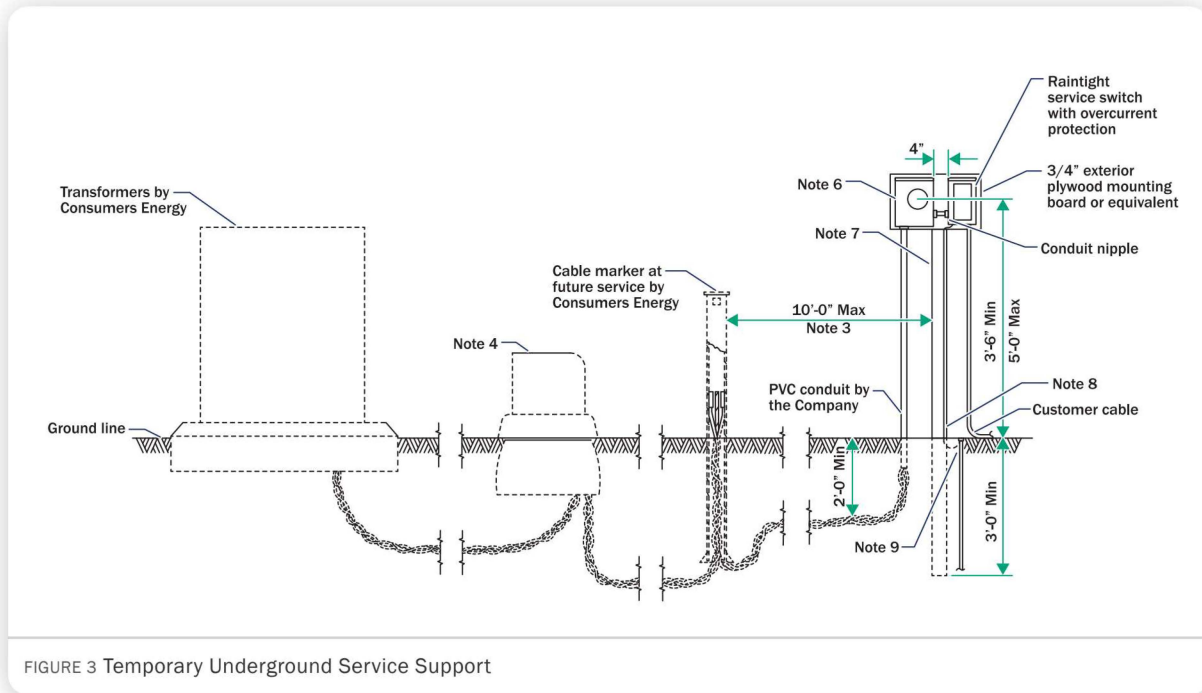

Notes

1. The customer shall install the Company's socket and shall furnish and install the service support, service switch and associated material. The service support location, designation by the Company, shall be 10'-0" or less from the nearest Company underground facility.
2. The Company will furnish and install the temporary service lateral and shall make the service connections and disconnections.
3. Temporary service should not be larger than 1/0 Aluminum.
4. Secondary junction pedestal or secondary connection cabinet or secondary junction vault by Consumers Energy.
5. 3/4 " exterior plywood mounting or equivalent.
6. Company's meter socket.
7. Customer-owned support 4" x4"x 8'-0" min long treated wood post or equivalent Refer to Note 1.
8. #6 bare (min) ground wire or equivalent connected to a 3/4" galvanized pipe or 5/8 " solid rod 8'-0" long or other recognized grounding electrode.
9. National Electric Code approved ground rod and clamp.

Single-Phase Installation with Service Drop Attached to Building

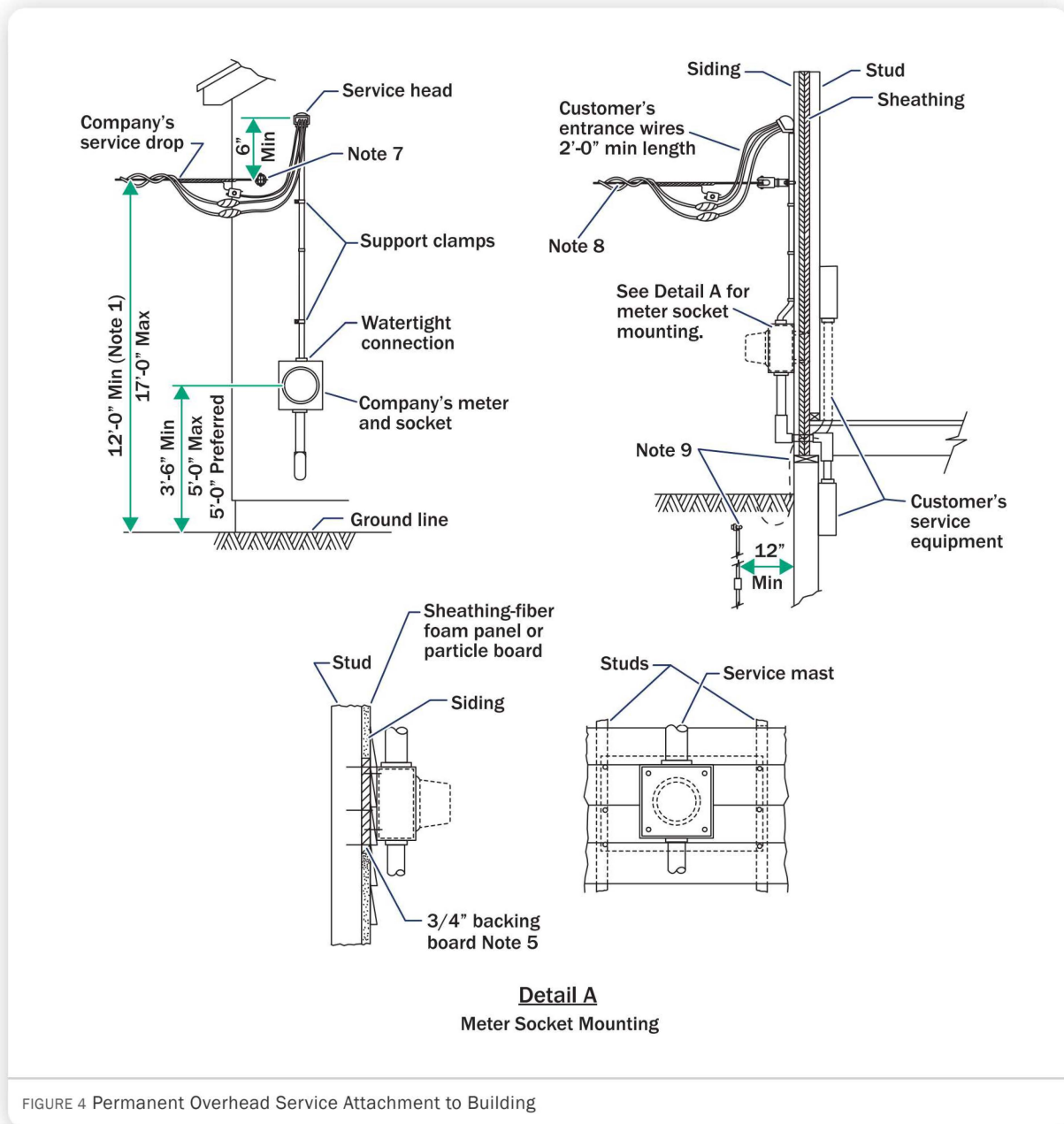



FIGURE 4 Permanent Overhead Service Attachment to Building

Notes

1. Consumers Energy will designate general location and required service height above ground. The maximum dimension concerns bucket truck accessibility. Before installing above 17ft consider that the location may be inaccessible by the bucket truck in the future.
2. Consumers Energy meter socket shall be fastened securely to building.
3. The customer must install a complete ground in accordance with the National Electric Code (NEC) and local inspector. Customer must not route the grounding conductor from the customer's main disconnect to the customer's ground rod by going through the meter socket. Variance from these installation requirements must be approved by a Consumers Energy engineering representative.
4. Variance from these installation requirements must be approved by a Consumers Energy engineering representative.
5. Secure backing board of pine or at least 2 studs flush with sheathing. Mount socket level and plumb with four #12 round head wood screws with at least 3/4" into backing.
6. Use of this service method requires that the building have a complete, permanent perimeter foundation.

7. Customer must provide a solid area of support under siding for service bracket installed by Consumers Energy. If sheathing is pine or plywood, mark location of nearest stud or plate. If sheathing is fiber, foam panel or partial board, securely fasten a backing plate (min 2" x 6") to studs and flush with outer surface of sheathing. Mark location on siding.
8. Only Consumers Energy authorized persons shall connect or disconnect service.

 **CAUTION**
Consumers Energy assumes no responsibility for damage or injury arising out of the use of these requirements.

Service Mast Installation Requirement for Building with 0'-8" Roof Overhang

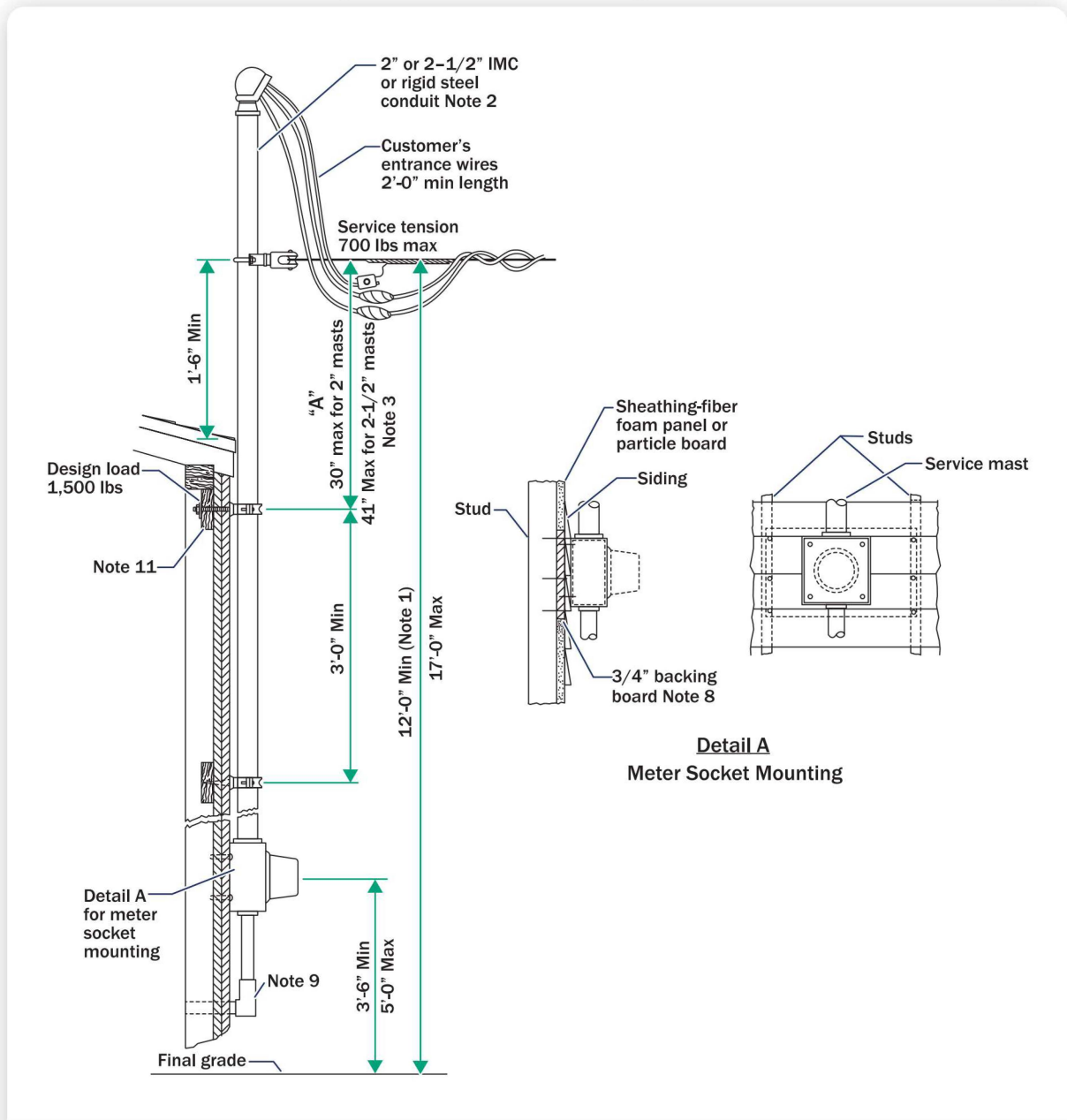

FIGURE 5 Building with 0'-8" Roof Overhang

Notes

1. Consumers Energy will designate general location and required service height above ground. The maximum dimension concerns bucket truck accessibility. Before installing above 17' consider that the location may be inaccessible by bucket in the future.
2. Mast shall be installed when necessary to provide required service height. If length is 10'-0" or less, it must be one piece galvanized rigid or intermediate (IMC) steel conduit. Coupling for lengths over 10'-0" shall be installed below the lower support.
3. Height (A) of service attachment above top support should be the minimum required to provide necessary service clearance above ground.
4. See Figure 6, Service Mast Installation Requirement for Building Exceeding 0'-8" Roof Overhang for wide overhang design.
5. for wide overhang design.
6. Consumers Energy meter socket shall be fastened securely to building.
7. The customer must install a complete ground in accordance with the National Electric Code (NEC) and local inspector. Customer must not route the grounding conductor from the customer's main disconnect to the customer's ground rod by going through the meter socket.
8. Variance from these installation requirements must be approved by a Consumers Energy engineering representative.
9. Secure backing board of pine or plywood to at least two studs flush with sheathing. Mount socket level and plumb with four #12 round head wood screws with at least 3/4" into backing.
10. Use of this service method requires that the building have a complete, permanent perimeter foundation.
11. See Figure 7, Service Mast Support Details in Drawings and Wiring Diagrams.

Service Mast Installation Requirement For Building Exceeding 0'-8" Roof Overhang

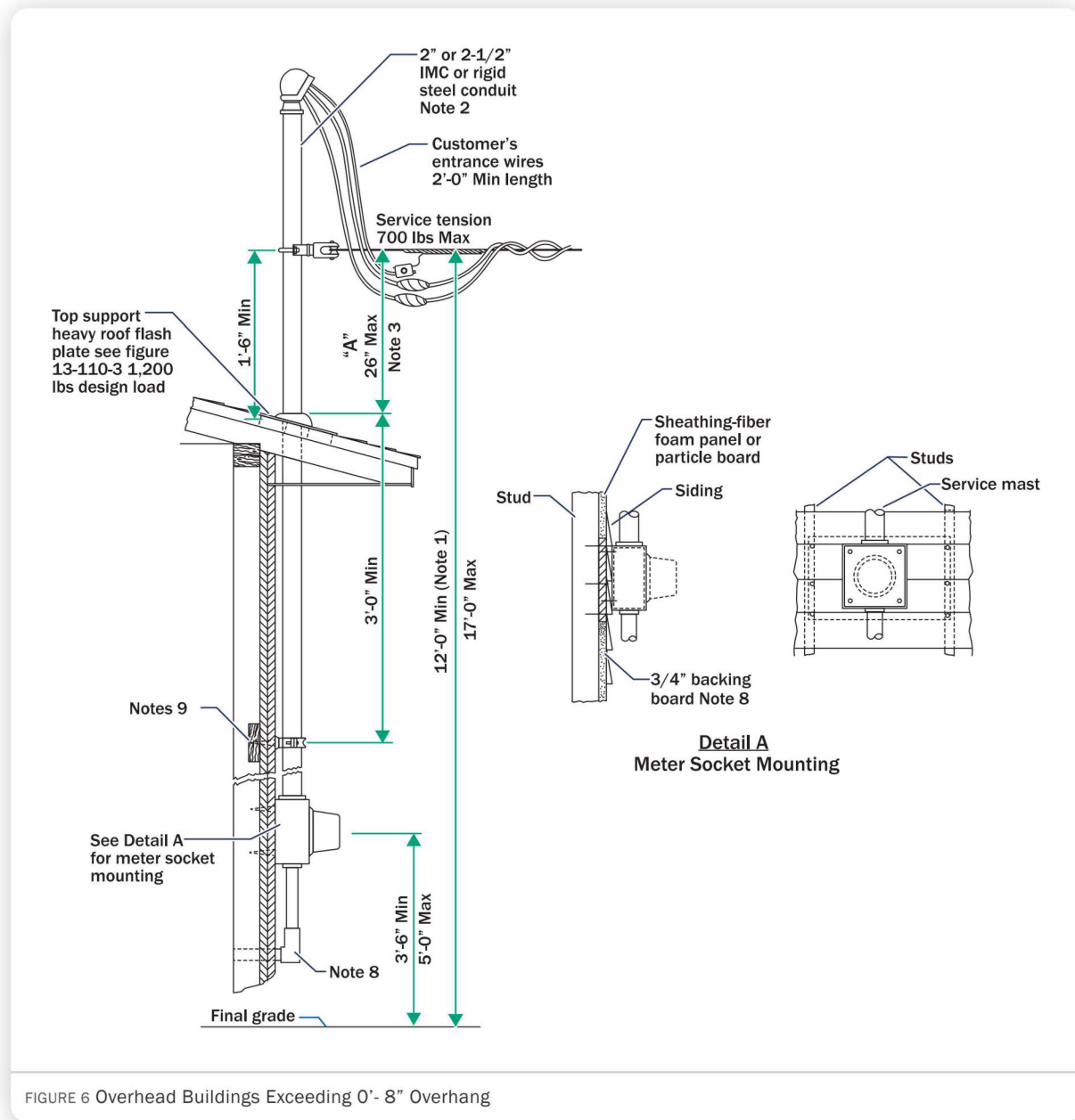

FIGURE 6 Overhead Buildings Exceeding 0'- 8" Overhang

Notes

1. Consumers Energy will designate general location and required service height above ground. The maximum dimension concerns bucket truck accessibility. Before installing above 17' consider that the location may be inaccessible by bucket truck in the future.
2. Mast must be installed when necessary to provide required service height. If length is 10' 0" or less, it must be one piece galvanized rigid or intermediate (IMC) steel conduit. Coupling for lengths over 10'-0" must be installed below the lower support.
3. Height "A" of service attachment above top support should be the minimum required to provide necessary service clearance above ground,
4. Consumers Energy meter socket must be fastened securely to building.
5. The Customer must install a complete ground in accordance with the NEC and local inspector. Customer must not route the grounding conductor from the customer's main disconnect to the customer's ground rod by going through the meter socket.
6. Variance from these installation requirements must be approved by a Consumers Energy engineering representative.
7. Secure backing board of pine or plywood to at least two studs flush with sheathing. Mount socket level and plumb with four #12 roundhead wood screws with at least 3/4" into backing.
8. Use of this service method requires that the building have a complete, permanent perimeter foundation.

Overhead Service Mast Support Details

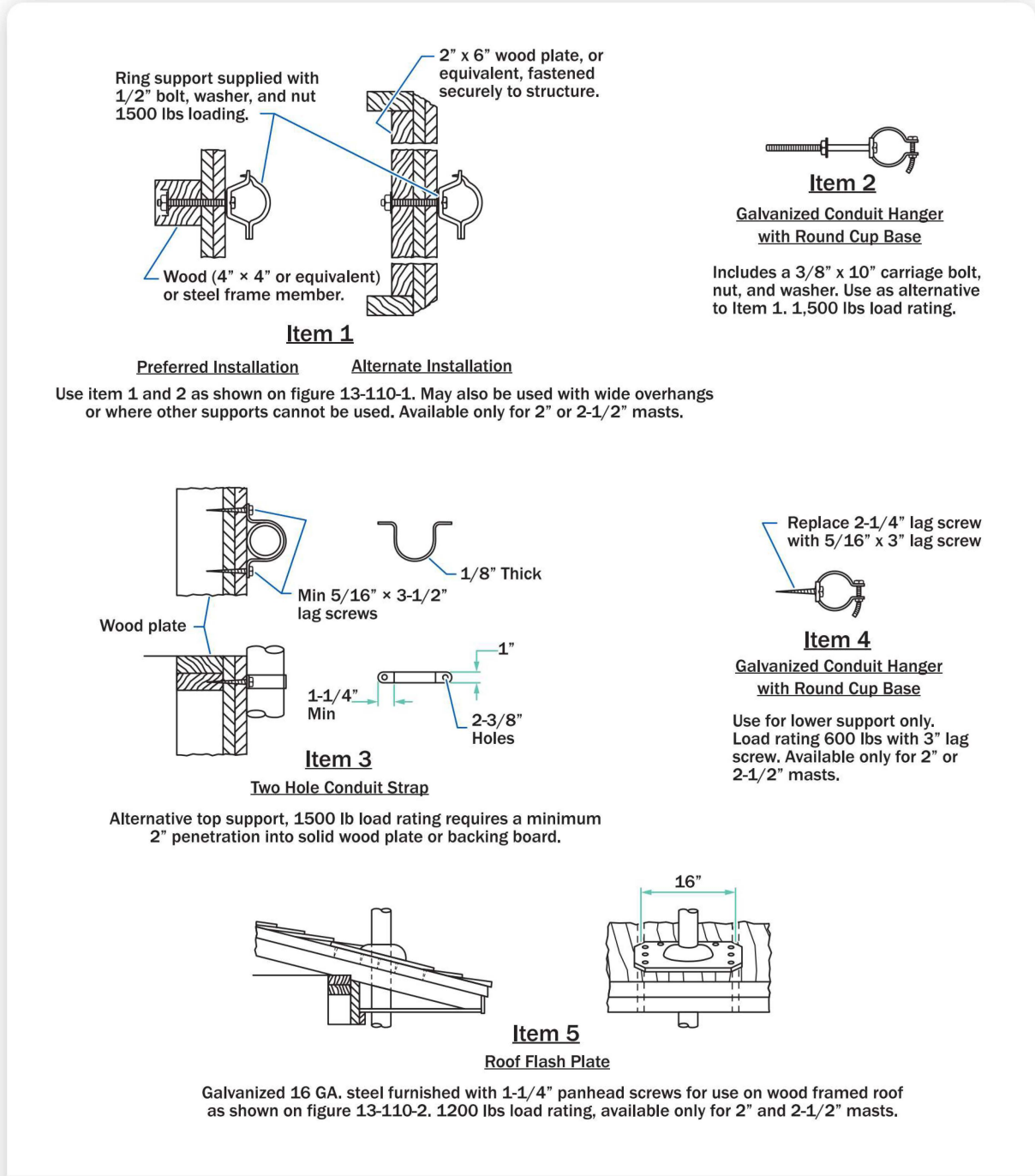

FIGURE 7 Service Mast Support Details

Residential Underground Service

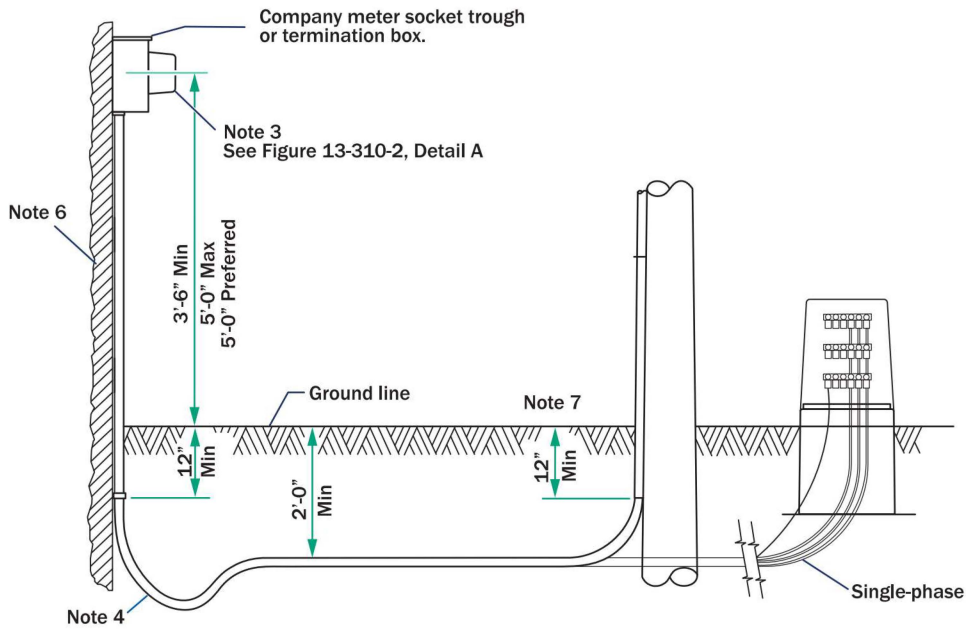

FIGURE 8 Residential Underground Service

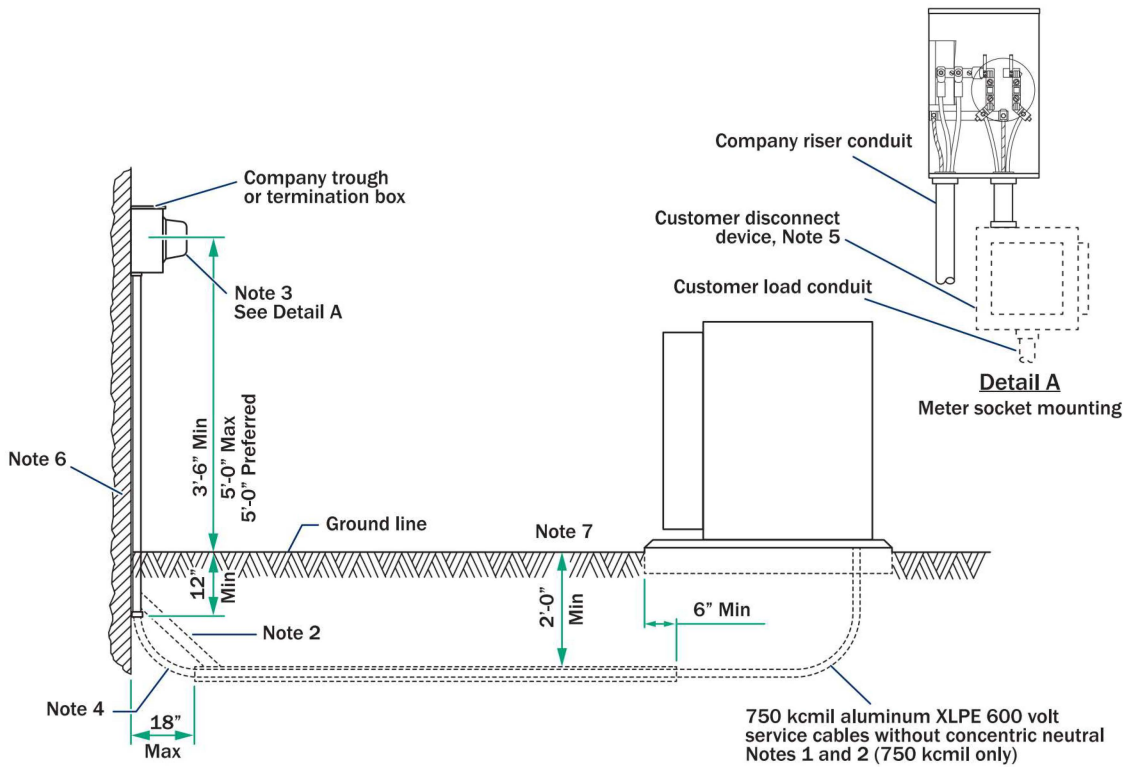
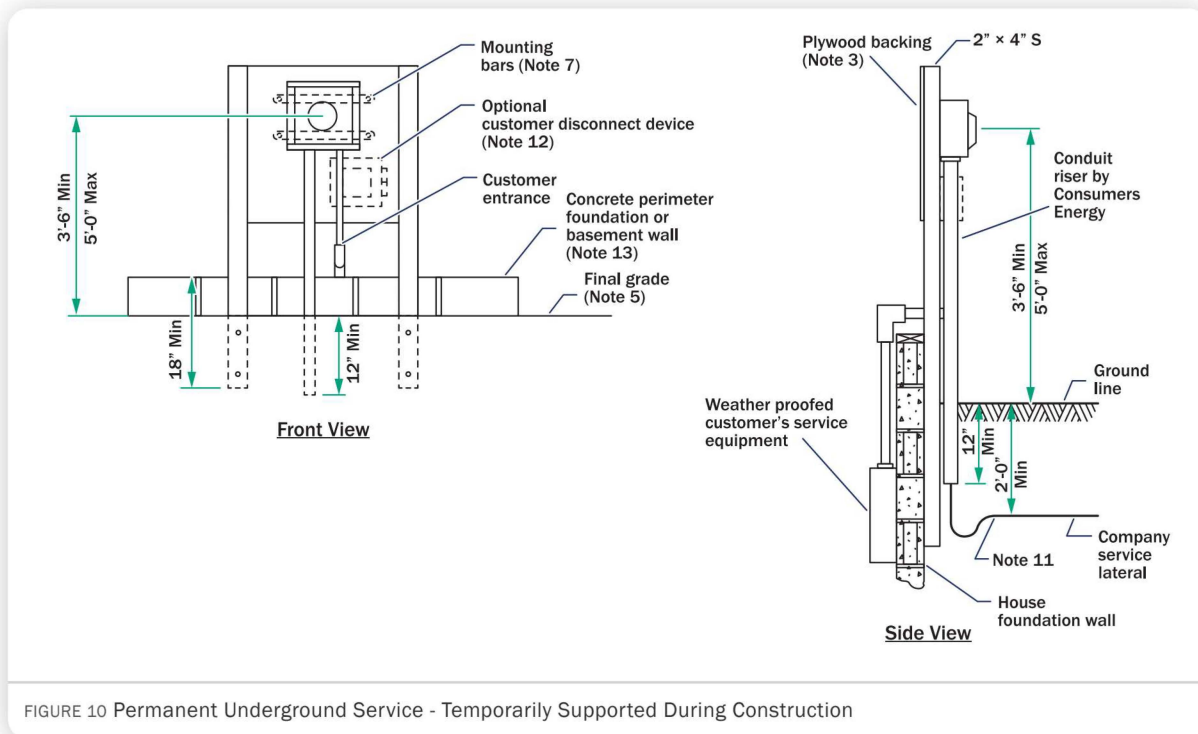

FIGURE 9 Residential Underground Service

Notes

1. One 10'-0" length maximum of polyethylene molding. For longer runs, use a continuous length of PVC, SCH 40 conduit.
2. Short piece of plastic molding with ends cut at an angle to fit against the riser conduit and molding (or conduit) if required for mechanical protection of the cable. Do not sweep the conduit up to the meter socket.
3. The complete installation will be furnished, owned, and installed by the Company except that the meter socket, trough, or termination box will be installed by the customer.
4. To prevent meter damage from the conductor settling, earth beneath the conductor should be level and well tamped. Leave as much slack as possible in the conductor at the riser.
5. If the customer disconnect device is required by local or National Electrical Code and is mounted outside, it shall be offset to provide space for Company riser conduit.
6. A customer dwelling or a business building must be on a complete, permanent foundation. See service pedestal standards if not.
7. Customer must grade property to within 3" of final grade along the route of service.

Permanent Underground Service (Temporarily Supported During Construction)



NOTE

Before using this support the customer shall obtain required electrical inspectors approval.

Notes

1. The customer shall securely install the meter socket and load conduit. Company will install, own and maintain the underground service lateral and riser conduit in accordance with its standard underground policy.
2. Customer shall install all wiring including complete ground in accordance with local or National Electrical Codes as applicable.
3. Customer to provide and install 2" x 4"s and plywood backing (3/8" minimum) to temporarily support the meter socket.
4. **DO NOT** route ground wire (from disconnect to ground) through the meter socket.
5. Customer must grade property to within 3" of final grade along the route of service.
6. The Company may deny connection to an improperly installed meter socket.

7. Mounting bars are to be picked up at Consumers Energy Electric Meter Department, Material Number 10030225.
8. There is a six month limit on time allowed for temporary support.
9. During construction the customer is responsible for damage to the meter, meter socket and meter support structure and associated equipment.
10. Customer to ensure that the meter socket is mounted level and plumb.
11. To prevent meter damage from conductor settling, earth beneath conductors should be leveled and well tamped, leave as much slack as possible in the conductor at the riser.
12. If customer disconnect device is mounted outside, it shall be offset to provide space for Company rise conduit.
13. Modular structures may qualify for this service method if they have a complete perimeter foundation. If not, use mobile home service method.

Permanent Underground Service (After Wall Construction)

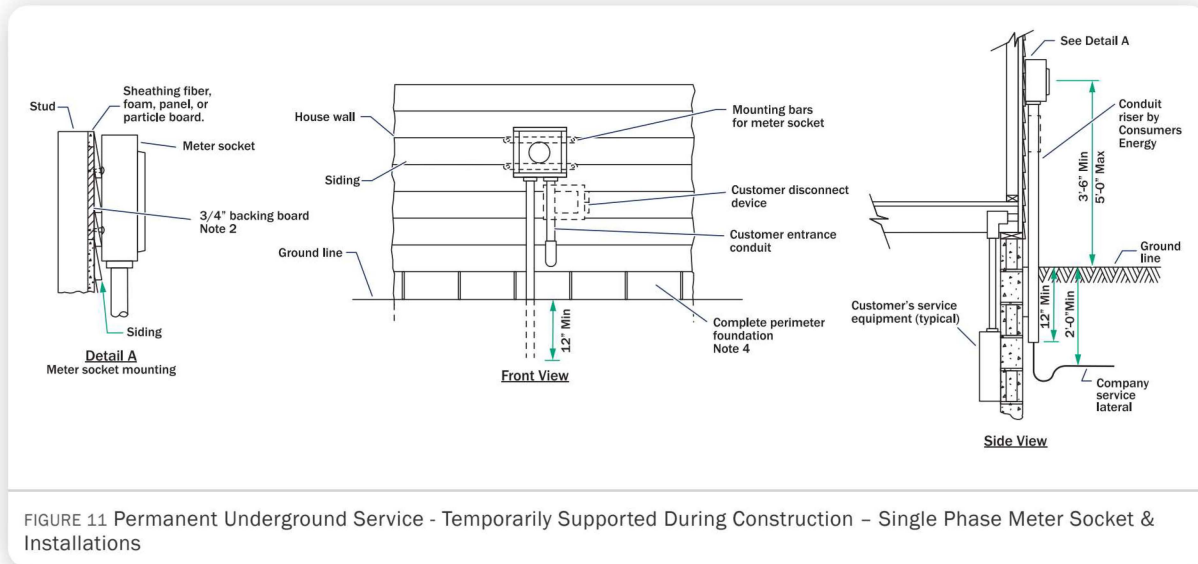

Notes

1. After installation of wall, customer will remove 2" x 4"s and plywood backing from 2" x 4"s.
2. Customer will secure backing board of pine or plywood to at least two studs flush with sheathing and mount meter socket level and plumb.
3. Customer is responsible for ensuring that meter socket is permanently mounted to backing board using mounting bars after the wall is constructed.
4. Modular structures may qualify for this service method if they have complete perimeter foundation. If not, use mobile home service method.
5. Customer must grade property to within 3" of final grade along the route of service.

Permanent Underground Service - Single-Phase Treated Wood Support

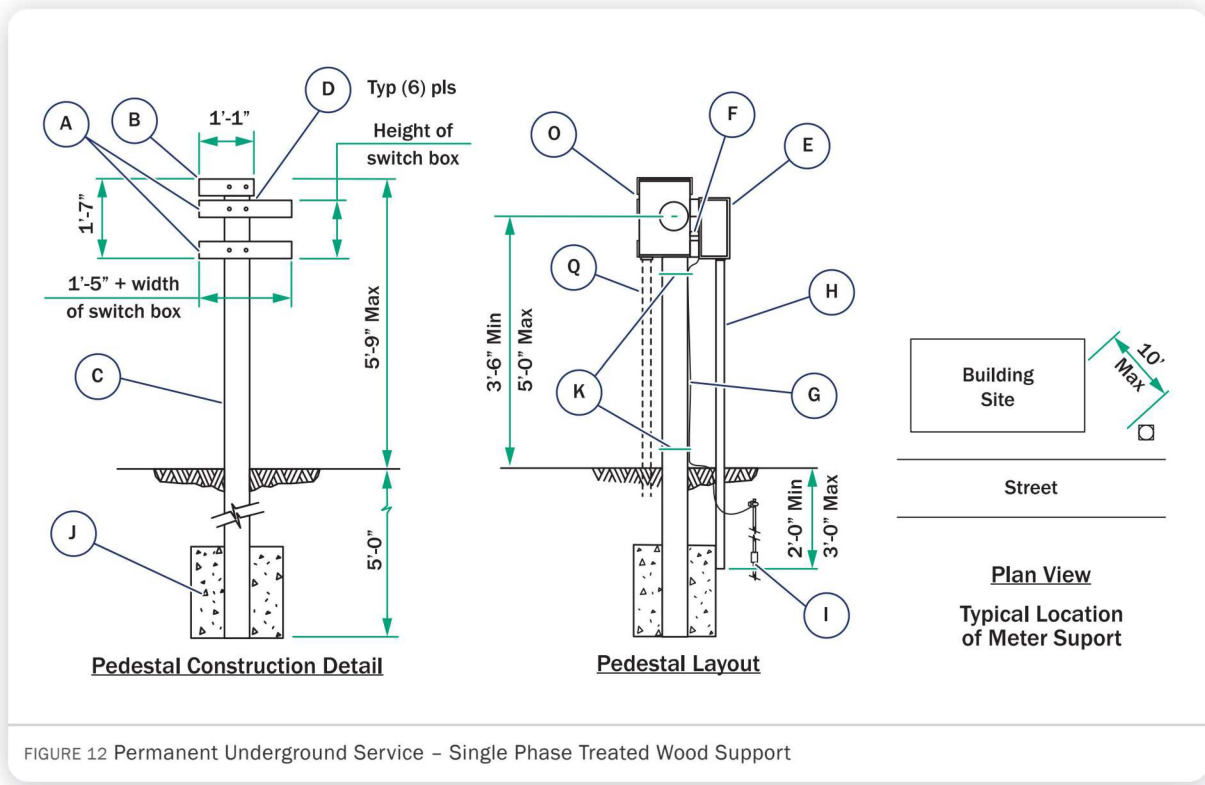

FIGURE 12 Permanent Underground Service – Single Phase Treated Wood Support

Item	Customer to Provide
	Description
A	Treated 2" x 4" x 1'-5" + width of switch box (Treatment rated for above ground (0.25 preservative per cubic foot (PCF) minimum))
B	Treated 2" x 4" x 1'-1" (Treatment rated for above ground 0.25 PCF minimum)
C	Treated timber rated for ground contact (0.40 PCF minimum (length 10'-9" maximum, 9'-3" minimum, 6" x 6" minimum))
D	Customer shall securely lag cross beams (Items A and B) to main support beam (Item C)
E	Switch box
F	Minimum 1" galvanized pipe nipple Minimum 1" ridged conduit locknut Minimum 1" grounding bushing
G	#6 (minimum) Bare copper ground wire
H	Customer conduit
I	5/8" Ground rod Ground rod clamp
J	Concrete
K	Nylon Ties

TABLE 2

Item	Stock No.	Consumers Energy to Provide
		Description
O**	10029609	200 A Meter socket
P	10028020	2" PVC Male adapter conduit
	10028882	2" Galvanized conduit Locknut
Q*	10028637	2" SCH 40 PVC conduit
R	10028853	2" Plastic conduit insert
TABLE 3		

Notes

1. The Electric Meter Standards Committee must approve any changes in the above design.
2. Consumers Energy and the Customer must mutually agree upon the meter location.
3. Customer must install the service pedestal plumb.
4. Customer shall provide a concrete footing of a minimum of 12" in diameter and 2' in length starting at the bottom of the hole as shown.
5. Consumers Energy reserves the right to refuse to connect either electric or gas to an improperly installed service support.
6. Customer shall install a complete ground in accordance with the National Electrical Code and local inspectors. Customer must not route grounding conductor (from disconnect to ground rod) through meter socket.
7. Customer must grade the property to within 3" of final grade along the route of the service.
8. Item "E" must be marked as being suitable for use as service equipment. The customer will own and install the cable from Item "E" to the load. The entire electrical installation must comply with the National Electrical Code and local inspectors.
9. This pedestal is intended for single residential and is not intended for use in mobile home parks. Refer to the mobile home park pedestal standard for this application.

Temporary Meter Support Combination Gas and Electric (To Avoid Winter Construction)

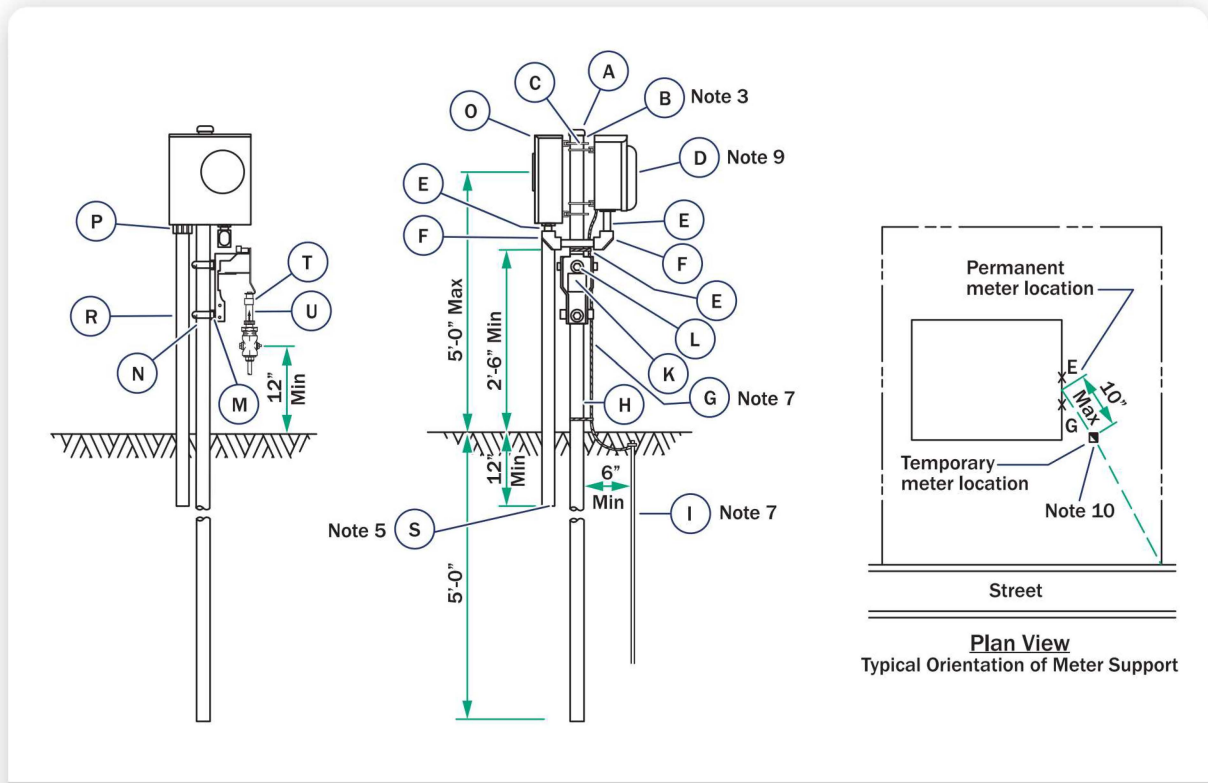

FIGURE 13 Temporary Meter Support Combination Gas & Electric (To Avoid Winter Construction) – Single Phase Meter Socket & Installations

Item	Customer to Provide
	Description
A	2" galvanized pipe cap - screw
B	Meter support - 2" galvanized pipe
C	Yoke, U-bolt clamp support for 2" pipe
D	Switch box
E	Pipe nipple galvanized 1" min size Ridged conduit locknut 1" min size Grounding bushing 1" min size
F	90° watertight elbow 1" min size
G	Ground wire - #6 min bare copper
H	Nylon ties
I	5/8" ground rod Ground rod clam
J	Concrete

TABLE 4

Item	Material No.	Consumers Energy to Provide
		Description
K	10090311	Gas meter bracket
Gas Meter Bracket Mounting Kit		
L	10016367	Screw
	10099101	Washer
	10099113	Lock washer
	10099115	Nut
M	10090220	Unistrut members
N	10090216	Unistrut pipe clamps
O**	10029609	200 A Meter socket
P	10028020	2" PVC Male adapter conduit
	10028882	2" Galvanized conduit locknut
R*	10028637	2" PVC SCH 40 conduit
S	10028853	2" Plastic conduit insert
T	10085150	Coupling
U	10089819	Excess flow valve
TABLE 5		

Notes

1. The Electric Meter Standards Committee must approve any changes in the design shown.
2. Consumers Energy and the Customer must mutually agree upon the meter location.
3. Customer must install the service pedestal plumb.
4. Customer shall provide a concrete footing of a minimum of 12" in diameter and two feet in length starting at the bottom of the hole as shown.
5. Consumers Energy reserves the right to refuse to connect either electric or gas service to an improperly installed service support.
6. Customer shall install a complete ground in accordance with the NEC and local inspectors. Customer must not route the grounding conductor (from the disconnect to the ground rod) through the meter socket.
7. Customer must grade the property to within 3" of final grade along the route of the service.
8. The installation, including the service equipment (Item D), must comply with the NEC as indicated by the MEC and approved by the AHJ (i.e. the electrical inspector). The customer is responsible for installing and maintaining all the equipment beyond the point of service i.e. the meter base, including the conductor from the load side of the meter to the load.
9. This pedestal is intended for single residential dwelling and is not intended for use in mobile home parks. See the mobile home park pedestal standard.

Mobile Home Underground Service Pedestal Combination Gas and Electric

Item	Material No.	Consumers Energy to Provide
		Description
K	10090311	Gas meter bracket
Gas Meter Bracket Mounting Kit		
L	10016367	Screw
	10099101	Washer
	10099113	Lock washer
	10099115	Nut
M	10090220	Unistrut members
N	10090216	Unistrut pipe clamps
O**	10029609	200 A Meter socket
P	10028020	2" PVC Male adapter conduit
	10028882	2" Galvanized conduit locknut
R*	10028637	2" PVC SCH 40 conduit
S	10028853	2" Plastic conduit insert
TABLE 7		

Notes

1. The Electric Meter Standards Committee must approve any changes in the above design.
2. Consumers Energy and the customer must mutually agree upon the meter location.
3. Customer must plumb and orient the service pedestal as shown in above sketch.
4. Customer must provide a concrete footing of a minimum of 6" in diameter and two foot length starting at the bottom of the hole as shown.
5. Consumers Energy reserves the right to refuse to connect either electric or gas service to an improperly install led service support.
6. Customer must install a complete ground in accordance with the National Electrical Code and local inspector. Customer must not route grounding conductor (from disconnect to ground rod) through meter socket.
7. Customer must grade property to within 3" of final grade along the route of the service.
8. The installation, including the service equipment (Item D), must comply with the NEC as indicated by the Michigan Electrical Code (MEC) and approved by the Authority Having Jurisdiction (AHJ) (i.e. the electrical inspector). The customer is responsible for installing and maintaining all the equipment beyond the point of service i.e. the meter base, including the conductor from the load side of the meter to the load.
9. Underground service to modular customer buildings should be provided in this manner if they do not have complete perimeter foundations.

Mobile Home Underground Service Pedestal Combination Gas and Electric Alternate Mount

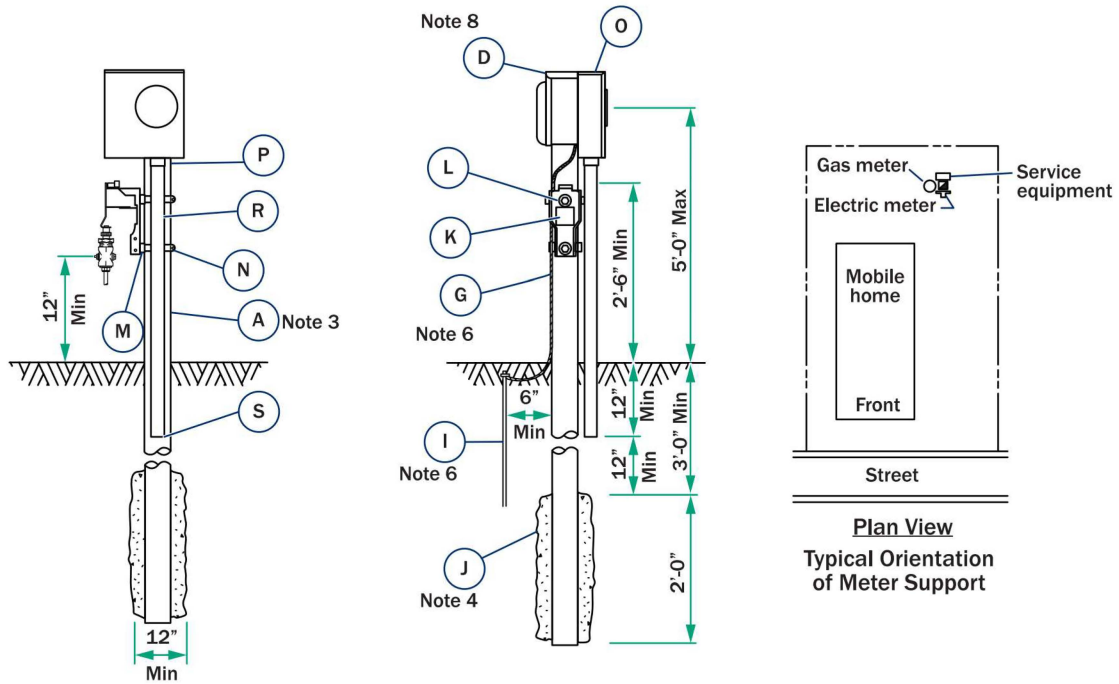

FIGURE 15 Mobile Home Underground Service Pedestal – Combination Gas and Electric Alternate Mount

Item	Customer to Provide
	Description
A	Mobile home meter-support
D	Service equipment
G	Ground wire #6 (min) bare copper
I	5/8" ground rod Ground rod
J	Concrete
TABLE 8	

Item	Material No.	Consumers Energy to Provide
		Description
K	10090311	Gas meter bracket
	Gas Meter Bracket Mounting Kit	
	10016367	Screw
L	10099101	Washer
	10099113	Lock washer
	10099115	Nut
M	10090220	Unistrut members
N	10090216	Unistrut pipe clamps
O**	10029609	200 A Meter socket
P	10028020	2" PVC Male adapter conduit
	10028882	2" Locknut
R*	10028637	2" PVC SCH 40 conduit
S	10028853	Insert bushing
TABLE 9		

Notes

1. The Electric Meter Standards Committee must approve any changes in the above design.
2. Consumers Energy and the customer must mutually agree upon meter location.
3. Customer must plumb and orient the service pedestal as shown in above sketch.
4. Customer must provide a concrete footing of a minimum of 12" in diameter and two foot length starting at the bottom of the hole as shown.
5. Consumers Energy reserves the right to refuse to connect either electric or gas service to an improperly installed service support.
6. Customer must install a complete ground in accordance with the National Electrical Code and local inspectors. Customer must not route grounding conductor (from disconnect to ground rod) through meter socket.
7. Customer must grade property to within 3" of final grade along the route of the service.
8. The installation, including the service equipment (Item D), must comply with the NEC as indicated by the MEC and approved by the AHJ (i.e. the electrical inspector). The customer is responsible for installing and maintaining all the equipment beyond the point of service i.e. the meter base, including the conductor from the load side of the meter to the load.
9. Underground service to modular customer buildings should be provided in this manner if they do not have complete perimeter foundations.

Mobile Home Underground Pedestal Electric Only

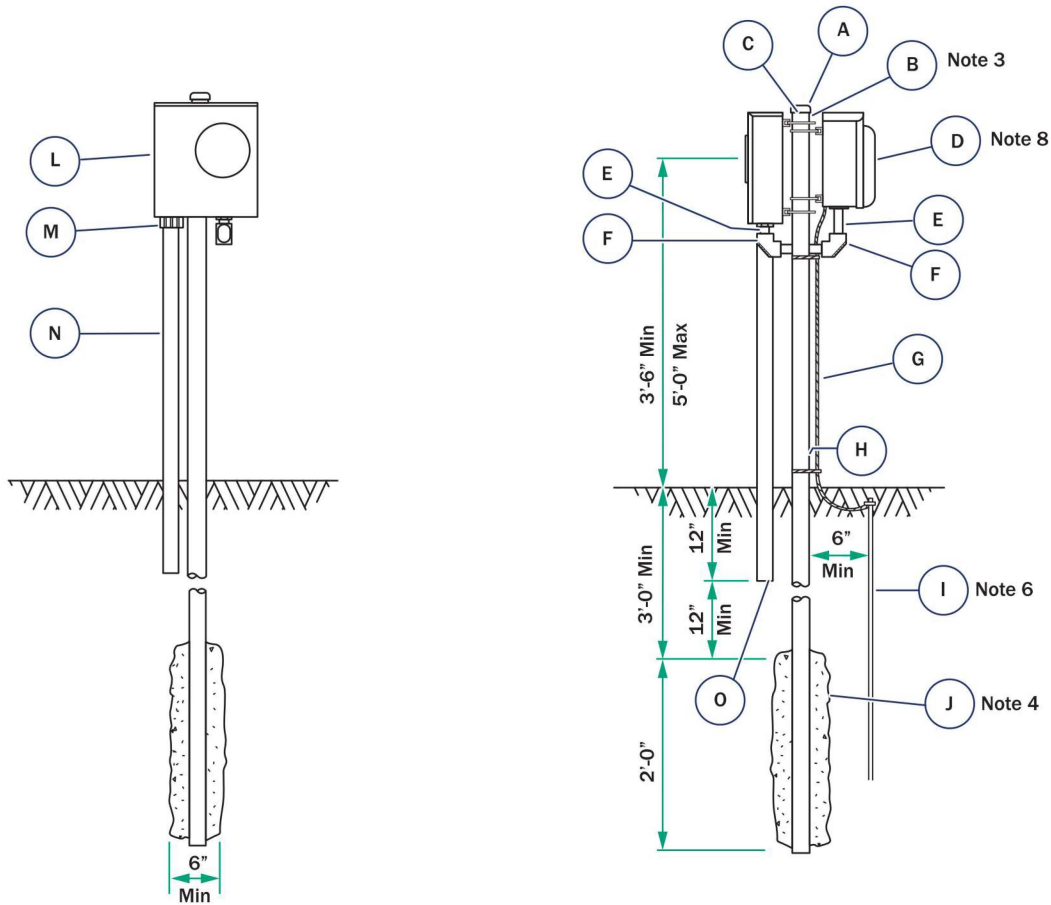

FIGURE 16 Permanent Support Single Phase – Single Phase Meter Socket and Installations

Item	Customer to Provide
	Description
A	2" Galvanized pipe cap
B	Meter support - 2" galvanized pipe
C	U-bolt clamp / yoke support for 2" pipe
D	Service equipment
E	Pipe nipple galvanized 1" minimum size Ridged conduit locknut 1" minimum size Grounding bushing 1" minimum size
F	90° watertight elbow 1" minimum size
G	Ground wire #6 (min) bare copper
H	Nylon ties
I	5/8" ground rod Ground rod clamp
J	Concrete

TABLE 10

Item	Material No.	Consumers Energy to Provide
Description		
L**	10029609	200 A Meter socket
M	10028020	2" PVC Male adapter conduit
	10028882	2" Galvanized conduit locknut
N*	10028637	2" SCH 40 PVC conduit
O	10028853	2" Plastic conduit insert
*Designed for a maximum of 3/C #3/0 AL cable, for larger cable use appropriate conduit size		
**Installed by customer		
TABLE 11		

Notes

1. The Electric Meter Standards Committee must approve any changes in the above design.
2. Consumers Energy and the customer must mutually agree upon the meter location.
3. Customer must install the service pedestal plumb.
4. Customer must provide a concrete footing of a minimum of 6" in diameter and two foot length starting at the bottom of the hole as shown.
5. Consumers Energy reserves the right to refuse to connect either electric or gas to an improperly installed service support.
6. Customer must install a complete ground in accordance with National Electrical Code and local inspectors. Customer must not route grounding conductor (from disconnect to ground rod) through the meter socket.
7. Customer must grade property to within 3" of final grade along the route of the service.
8. The installation, including the service equipment (Item D), must comply with the NEC as indicated by the Michigan Electrical Code (MEC) and approved by the Authority Having Jurisdiction (AHJ) (i.e. the electrical inspector). The customer is responsible for installing and maintaining all the equipment beyond the point of service i.e. the meter base, including the conductor from the load side of the meter to the load.

Central Point Distribution Overhead Service Pole with Secondary

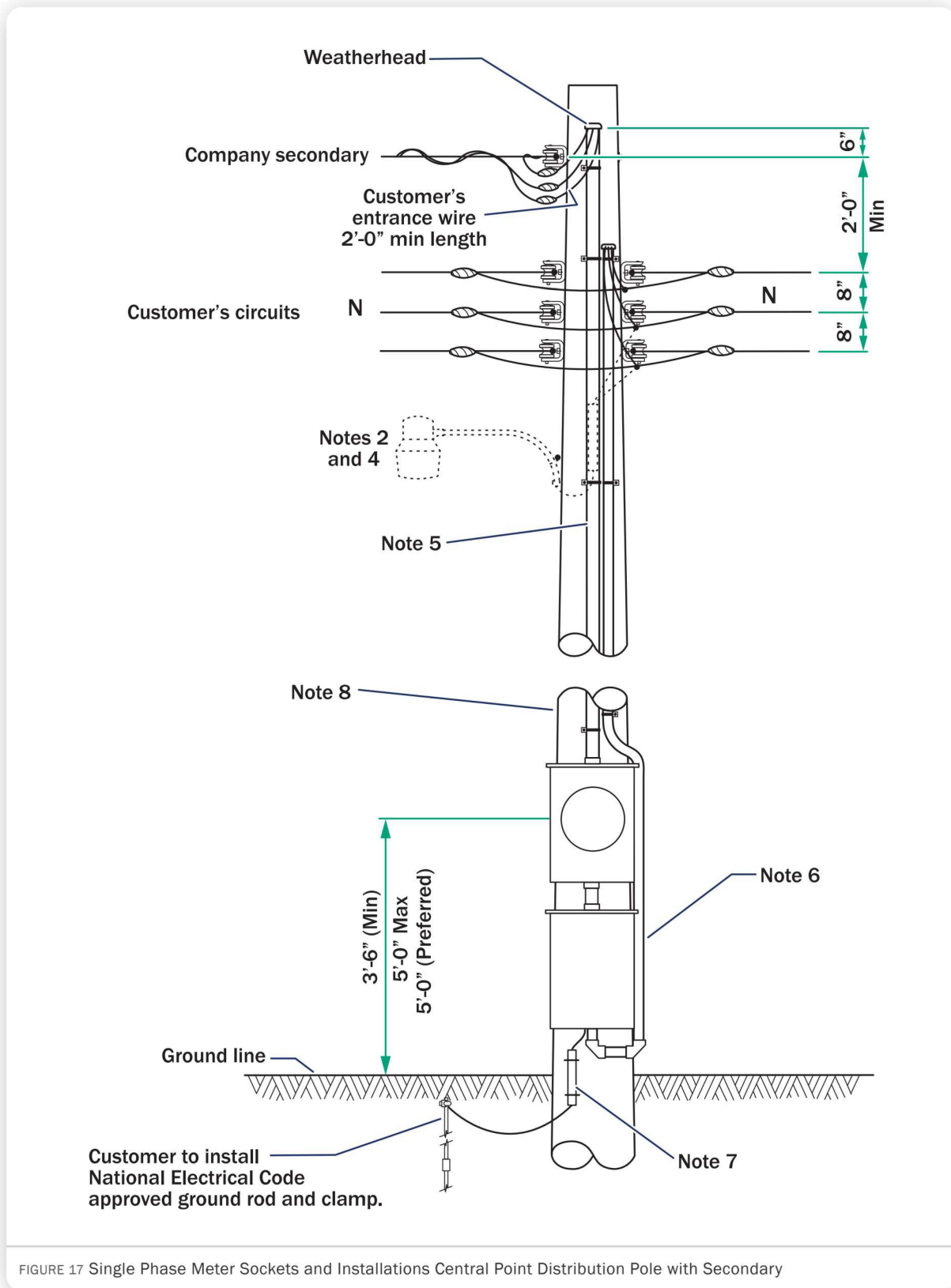

FIGURE 17 Single Phase Meter Sockets and Installations Central Point Distribution Pole with Secondary

Notes

1. Consumers Energy will furnish and install the pole in a mutually agreeable central location, furnish the meter socket and connect the service when customer installation is complete and approved. The customer must furnish all other wiring and equipment and install it with the meter socket.
2. Customer's lighting unit may be installed above customers wiring provided the top of the fixture is a minimum of 2'-0" below Consumers Energy's secondary attached to pole.

3. Central point distribution facilities are available only to residential farm service rate customers where a permanent residence exists.
4. Typical location of customer's mercury or sodium vapor lighting unit when used.
5. Single conductors in metallic or heavy wall (Sched 40) PVC conduit. Conductors must have a capacity of 200 Amperes as determined by the National Electrical Code.
6. Weatherproof dead front disconnect or transfer switch suitable for use as service equipment 200 ampere minimum (by customer)
7. #6 (min) bare copper ground wire covered by molding (provided by customer)
8. The customer must attach company meter socket and service switch securely to pole.

Central Point Distribution Overhead Service Pole with Transformer

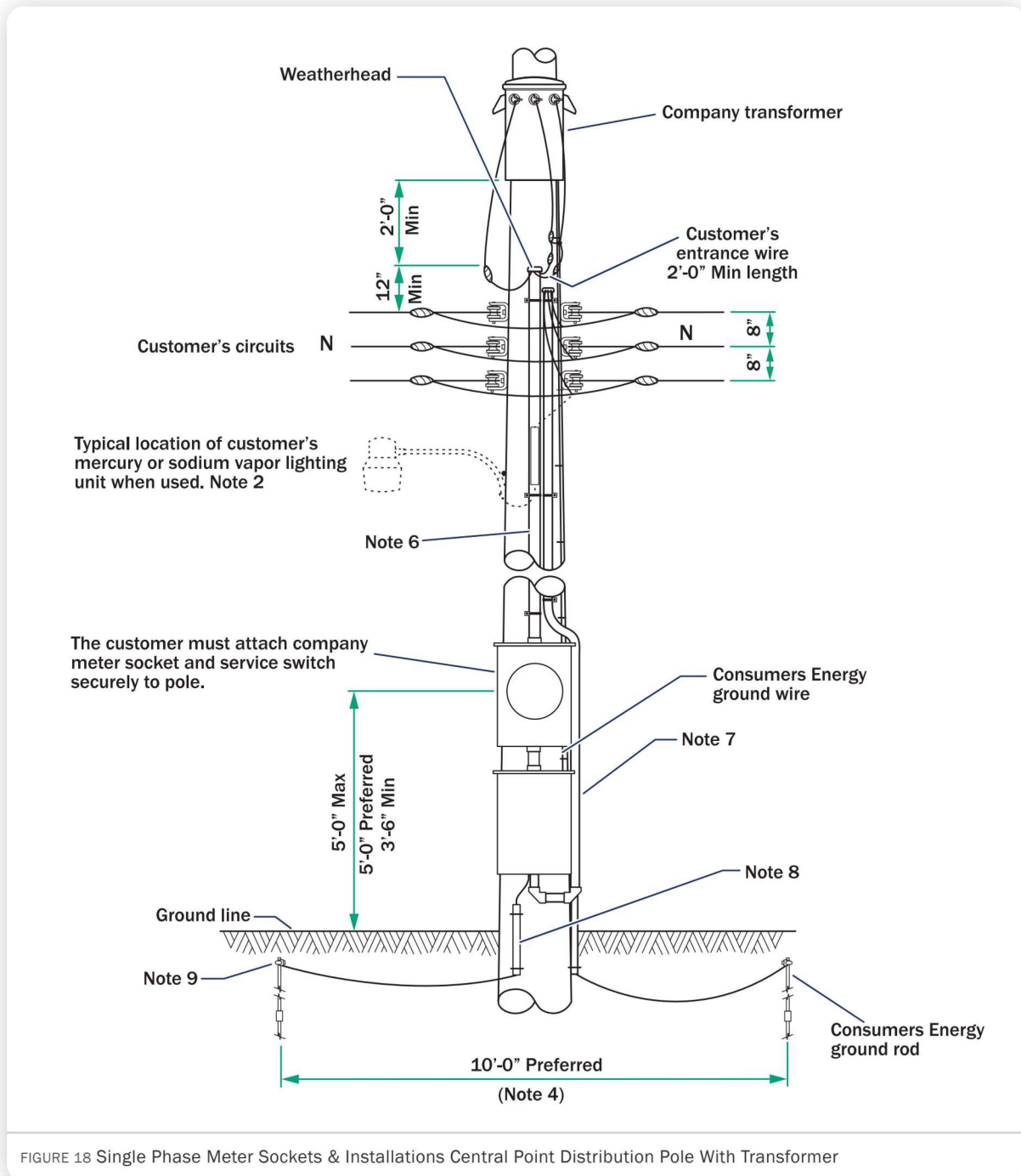

Notes

1. Consumers Energy will furnish and install the pole, transformer and lightning arrester ground in a mutually agreeable central location, furnish the meter socket and connect the service when customer installation is complete and approved, The customer must furnish all other wiring and equipment and install it with the meter socket.
2. Customer's lighting unit may be installed above customers wiring provided the top of the fixture is a minimum of 3'-0" below any Consumers Energy equipment mounted on the pole.
3. Central point distribution facilities are available only to residential farm service rate customers where a permanent residence exists.
4. NESC requires a minimum 6'-0" ground rod spacing, 10'-0" is preferred.
5. Central Point Distribution Overhead Service Pole with Transformer
6. Single conductors in metallic or heavy wall (Sched 40) PVC conduit. Conductors must have a capacity of 200 amperes as determined by the National Electrical Code
7. Weatherproof deadfront disconnect or transfer switch suitable for use as service equipment 200 ampere minimum (by customer)
8. #6 (min) bare copper ground wire cover by molding (provided by customer).
9. Customer to install National Electrical Code approved ground rod and clamp separate from Consumers Energy ground rod.

Central Point Distribution URD - Preferred Standard

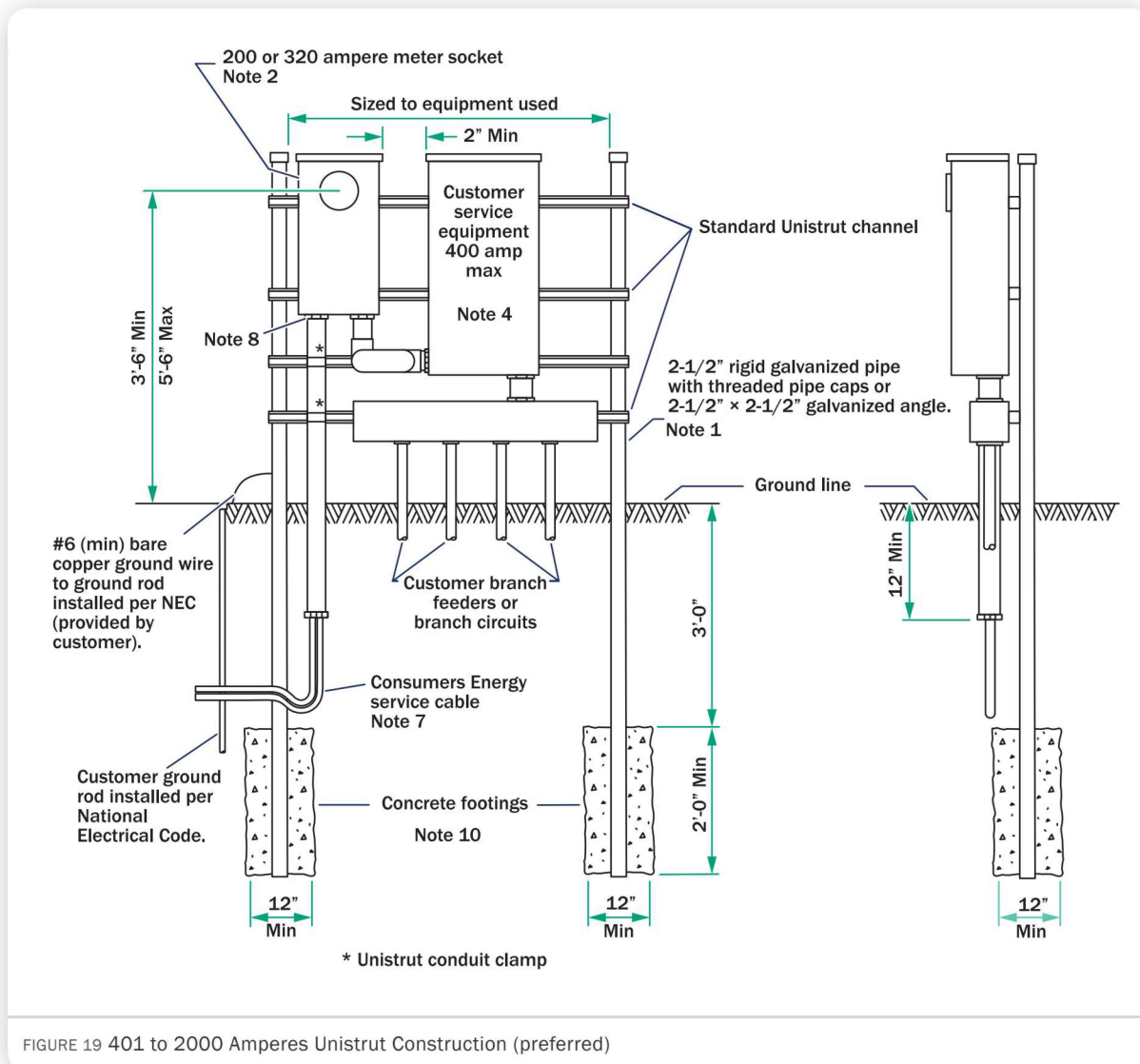

Notes

Printed on: 04/07/2022 | This version is only valid if the revision date matches the online version.

1. The customer is to provide metering and equipment support as shown. The customer is responsible for installing and maintaining all the equipment beyond the point of service i.e. the meter base, including the conductor from the load side of the meter to the load.
2. Consumers Energy is to furnish, and customer is to install, a 200 or 320 A self-contained meter socket. No more than one set of service entrance conductors are allowed to be terminated in the 200 A meter socket. No more than two sets of service entrance conductors can be terminated in the 320 A meter socket.
3. All equipment is to be of weatherproof construction or enclosed in a weatherproof cabinet.
4. The installation, including the service equipment, must comply with the National Electrical Code (NEC) as indicated by the Michigan Electrical Code (MEC) and approved by the Authority Having Jurisdiction (AHJ) (i.e. the electrical inspector).
5. Part of the equipment may be mounted on the opposite side of the panel to the meter to conserve space.
6. The exterior wall of an outbuilding may be used for the meter installation with customer equipment mounted either on the exterior or on the interior immediately adjacent to the point of entrance to the building.
7. To prevent meter damage from the conductor settling, earth beneath the conductor should be level and well tamped. Leave as much slack as possible in the conductor at the riser.
8. Install a grounding bushing and bond to the grounding lug only when steel conduit is utilized.
9. When installing a separate secondary ground, wiring methods must comply with Consumers Energy's standards.
10. Customer must provide a concrete footing with a minimum 12" diameter and two foot height.

Central Point Distribution URD - Alternate Standard

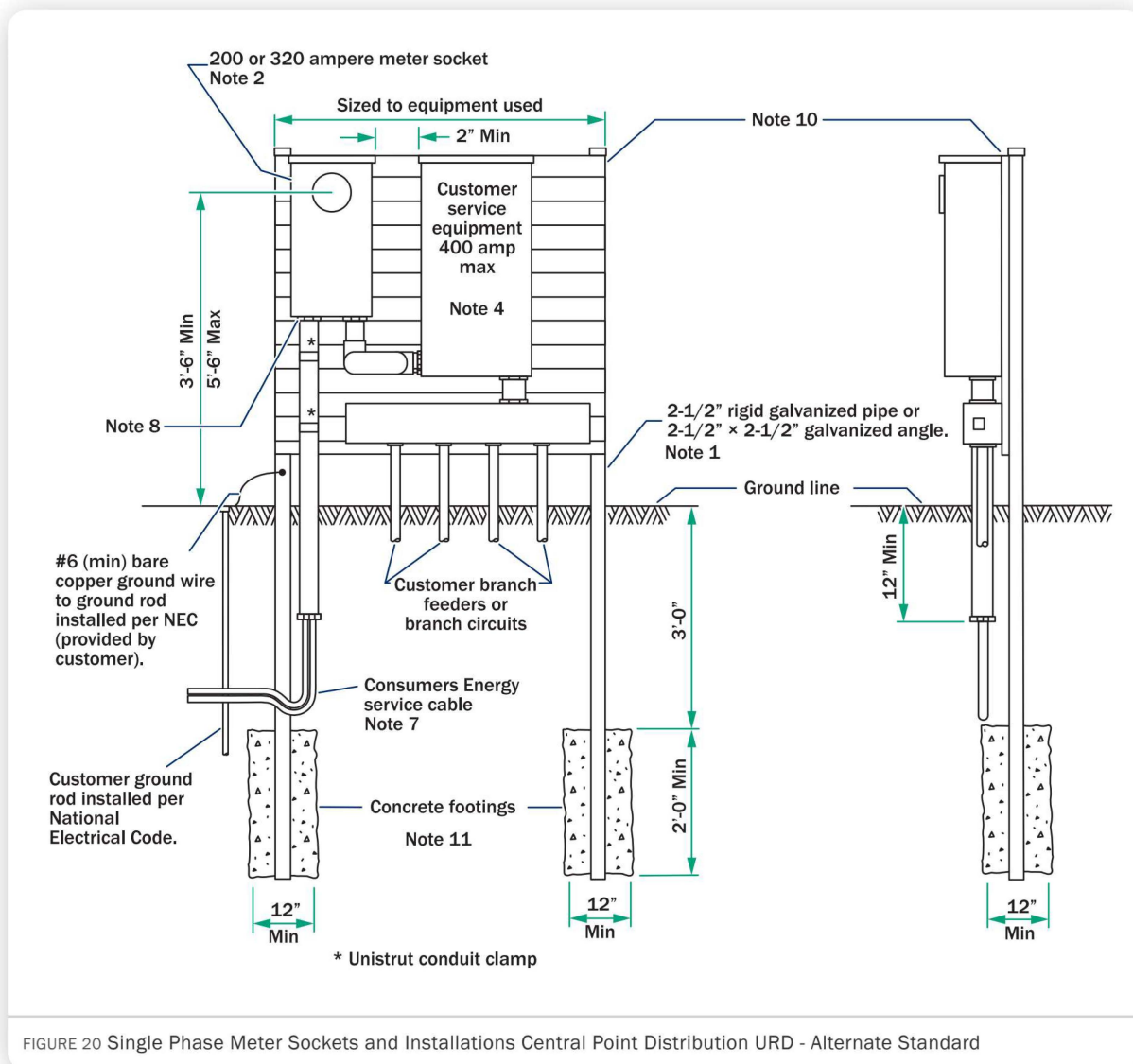

Notes

1. The customer is to provide metering and equipment support as shown. The customer is responsible for installing and maintaining all the equipment beyond the point of service i.e. the meter base, including the conductor from the load side of the meter to the load.
2. Consumers Energy is to furnish, and customer is to install, a 200 or 320 A self-contained meter socket. No more than one set of service entrance conductors are allowed to be terminated in the 200 A meter socket. No more than two sets of service entrance conductors can be terminated in the 320 A meter socket.
3. All equipment is to be of weatherproof construction or enclosed in a weatherproof cabinet.
4. The installation, including the service equipment, must comply with the National Electrical Code (NEC) as indicated by the Michigan Electrical Code (MEC) and approved by the Authority Having Jurisdiction (AHJ) (i.e. the electrical inspector).
5. Part of the equipment may be mounted on the opposite side of the panel to the meter to conserve space.
6. The exterior wall of an outbuilding may be used for the meter installation with customer equipment mounted either on the exterior or on the interior immediately adjacent to the point of entrance to the building.
7. To prevent meter damage from the conductor settling, earth beneath the conductor should be level and well tamped. Leave as much slack as possible in the conductor at the riser.
8. Install a grounding bushing and bond to the grounding lug only when steel conduit is utilized.
9. When installing a separate secondary ground, wiring methods must comply with Consumers Energy's standards.
10. The preferred construction method is with 2" × 6" pressure treated, tongue and groove planks. An alternate construction method is with 5/4" × 6" pressure treated deck planks. The minimum specifications for pressure treated lumber planks used above ground is 0.25 CC (PCF).
11. Customer must provide a concrete footing with a minimum 12" diameter and two foot height.

Central Point Distribution URD 401 – 2,000 Ampere Unistrut Construction (preferred)

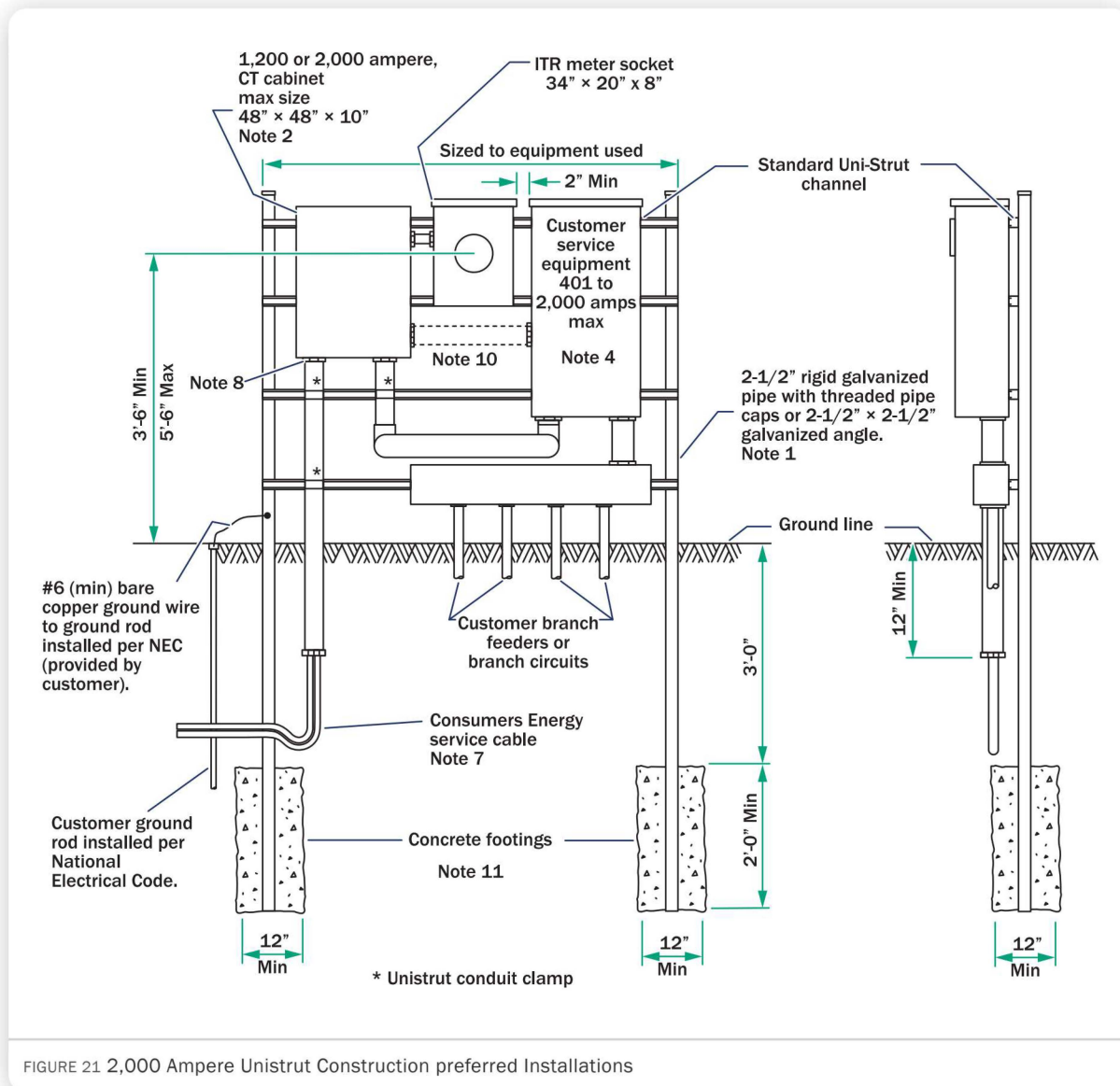

Notes

1. The customer is to provide metering and equipment support as shown. The customer is responsible for installing and maintaining all the equipment beyond the point of service i.e. the meter base, including the conductor from the load side of the meter to the load
2. Consumers Energy is to furnish, and customer to install, a 1,200 or 2,000 A CT cabinet and an ITR meter socket. No more than three conductors per phase in a 1,200 A CT cabinet, or five conductors per phase in a 2,000 A CT cabinet of service entrance conductors, are allowed to be terminated in the CT cabinet.
3. All equipment is to be of weatherproof construction or enclosed in a weatherproof cabinet.
4. The installation, including the service equipment, must comply with the NEC as indicated by the MEC and approved by the AHJ (i.e. the electrical inspector).
5. Part of the equipment may be mounted on the opposite side of the panel to the meter to conserve space.
6. The exterior wall of an outbuilding may be used for the meter installation with customer equipment mounted either on the exterior or on the interior immediately adjacent to the point of entrance to the building.
7. To prevent meter damage from the conductor settling, earth beneath the conductor should be level and well tamped. Leave as much slack as possible in the conductor at the riser.
8. Install a grounding bushing and bond to the grounding lug only when steel conduit is utilized.
9. When installing a separate secondary ground, wiring methods must comply with Consumers Energy's standards.
10. Alternate route for feeder conductors.

11. Customer must provide a concrete footing with a minimum 12" diameter and two foot height.

Attachment of Metering Equipment to Buildings

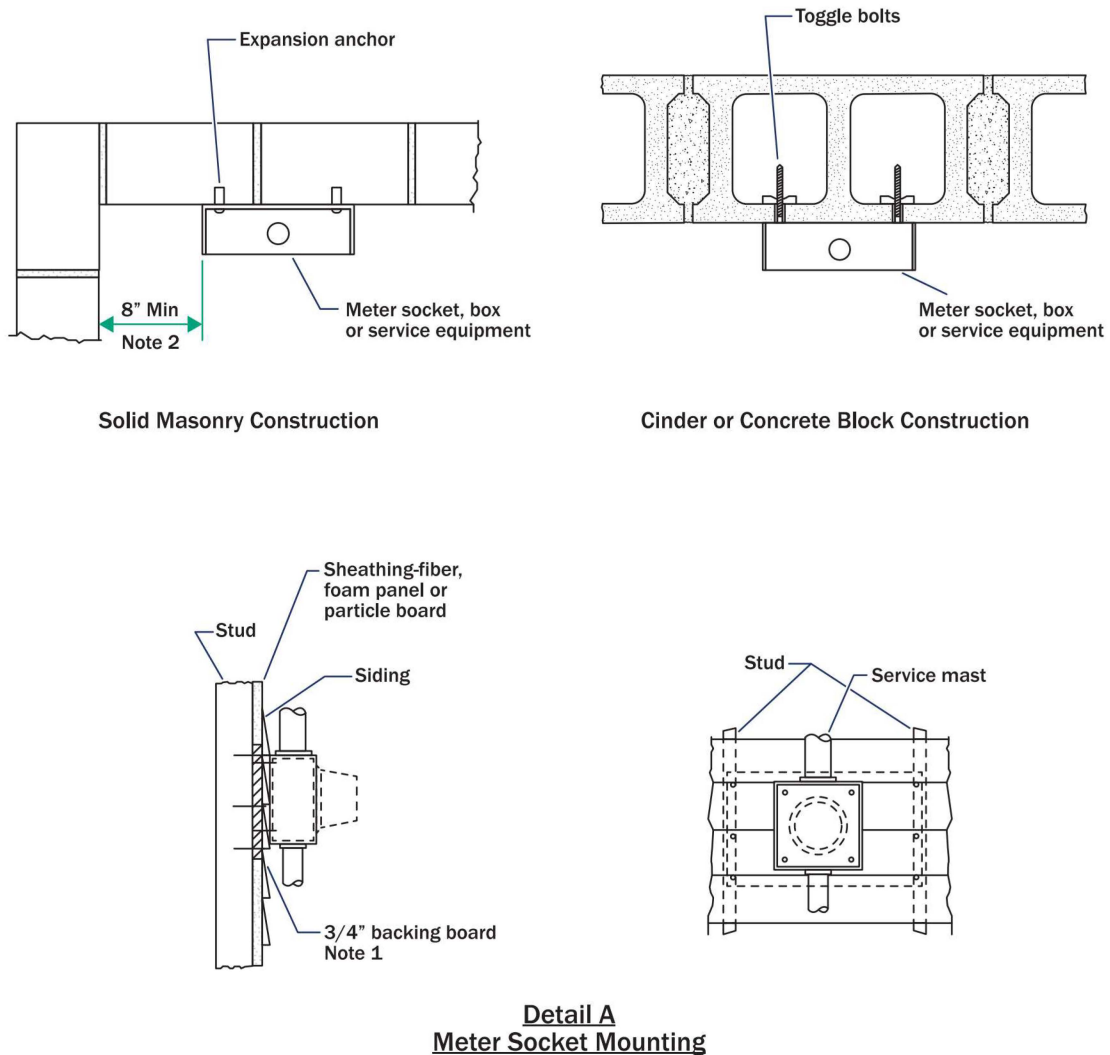

FIGURE 22 Attachment of Metering Equipment to Buildings – Single Phase Meter Socket and Installations

Notes

1. Install meter sockets so that the socket front shall be in a vertical plane and the meter when mounted shall be in a true vertical and horizontal position. Secure backing board of pine or plywood to at least 2 studs flush with sheathing. Mount socket with four #12 round head wood screws with at least 3/4" into backing.
2. Maintain a 4' readily accessible space in front of the meter. **DO NOT** locate meter socket within 8" of a right-angle construction.
3. Sockets and service entrance conduit or cable shall not be concealed or embedded in building walls.

Wiring Diagram for 4-Jaw Meter Socket for Self-Contained Meter Overhead Distribution

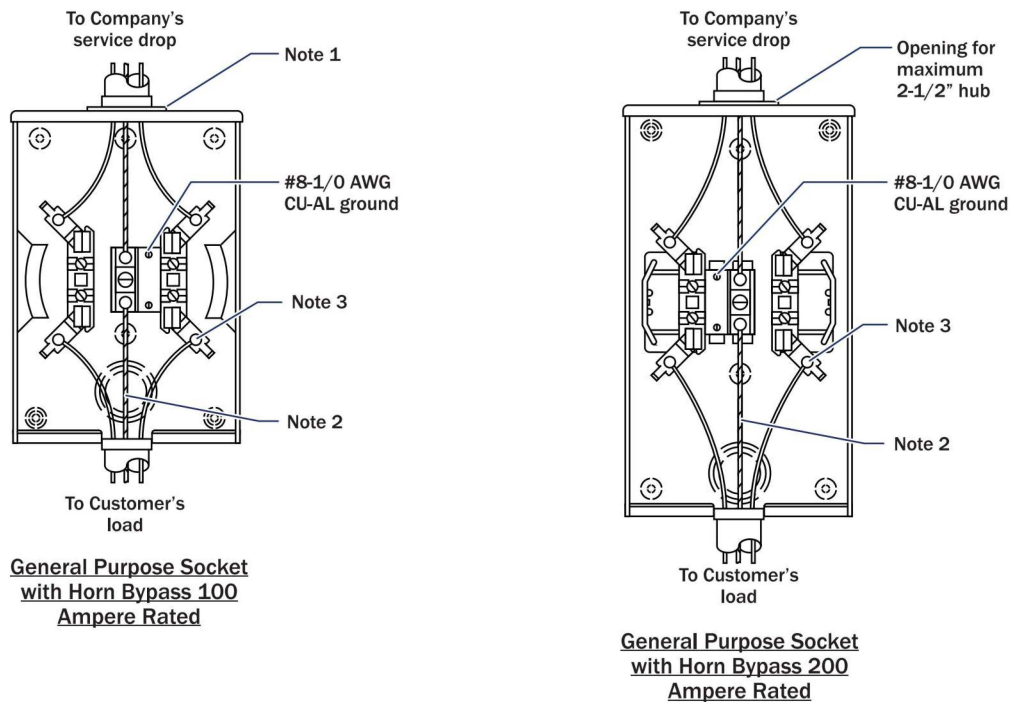

FIGURE 23 Wiring Diagram for 4-Jaw Meter Socket for Self-Contained Meter Overhead Distribution

Notes

1. Hub opening. Hub sizes available. 1-1/4", 2" and 2-1/2"
2. Neutral conductor must be connected to customer's ground at service equipment. Customer must install a complete ground in accordance with National Electrical Code and local inspectors.
Customer must not route grounding conductor (from disconnect to ground rod) through meter socket.
3. Wire terminations:
 - a. 200 ampere: #2-250 MCM AWG CU-AL line, load and neutral (6) places.
 - b. 100 ampere: #6-1/0 AWG CU-AL line, load and neutral (6) places.

Wiring Diagram for 4-Jaw Meter Socket for Self-Contained Meter for Underground Services

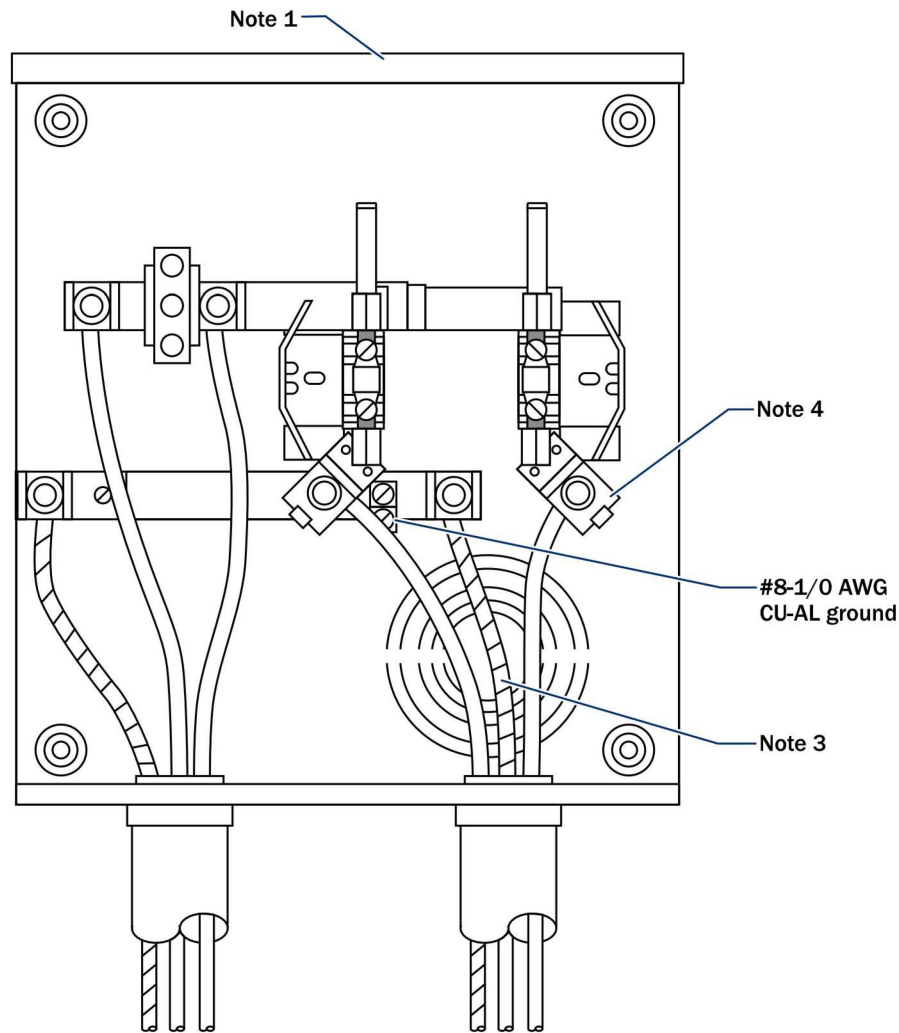
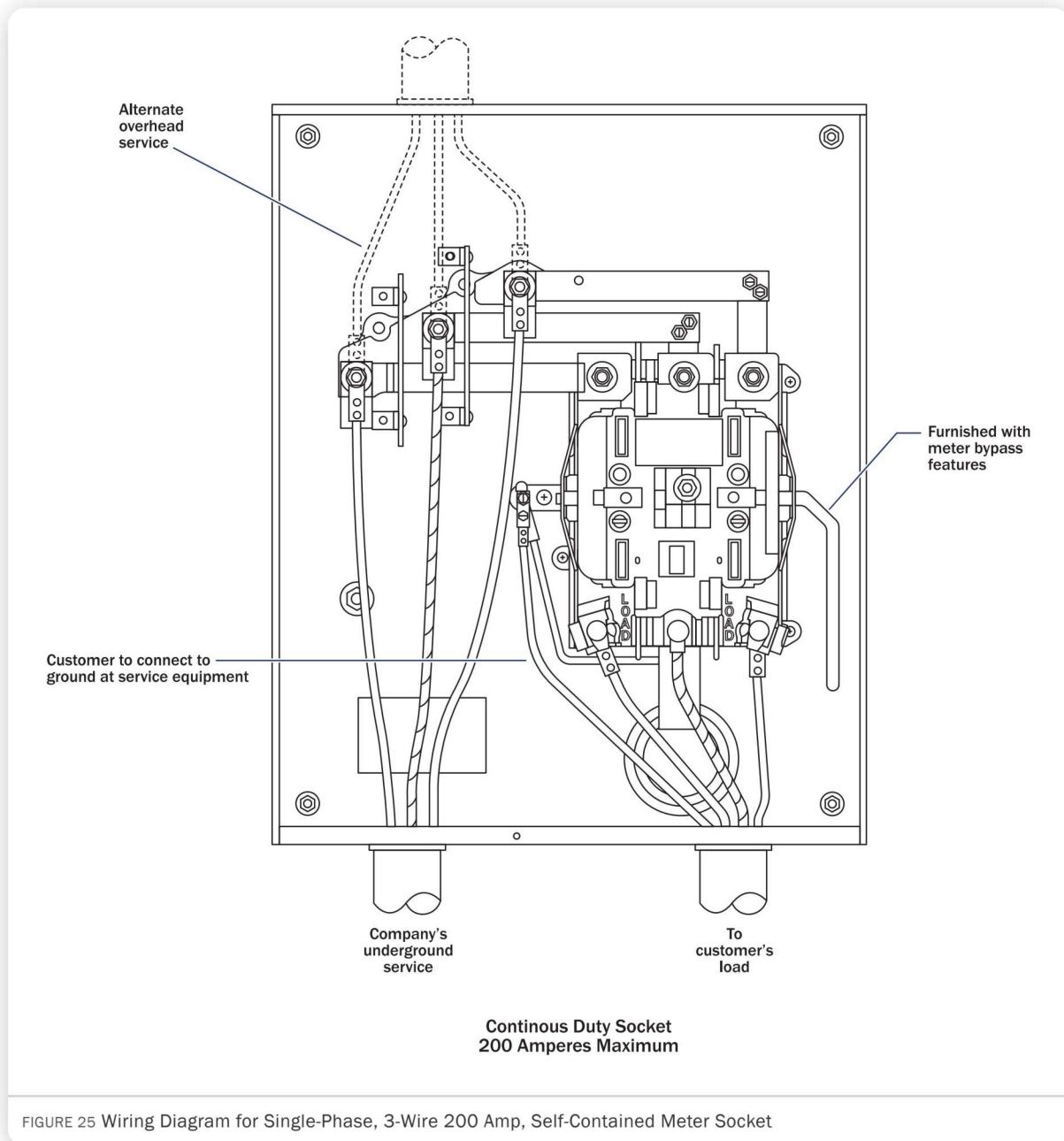

FIGURE 24 Wiring Diagram for 4-Jaw Meter Socket for Self-Contained Meter Underground Distribution

Notes

1. Socket rating available 200 ampere maximum general purpose with horn bypass feature.
2. Neutral conductor must be connected to customer's ground at service equipment. Customer must install a complete ground in accordance with National Electrical Code and local inspectors.
Customer must not route grounding conductor (from disconnect to ground rod) through meter socket.
3. #4-350 MCM AWG CU-AL line, load and neutral (6) places.

Wiring Diagram for Single-Phase, 3-Wire 200 Amp, Self-Contained Meter Socket



Notes

1. This socket is for use with 200 ampere, 3-wire, single-phase, 120/240 volts.
2. Terminations are designed for only one conductor per phase.
3. Customer to connect to ground at service equipment. Customer must install a complete ground in accordance with National Electrical Code and local inspectors.
Customer must not route grounding conductor (from disconnect to ground rod) through meter socket.

Wiring Diagram for Single-Phase, 3-Wire, 400 Amp, Self-Contained Meter Socket

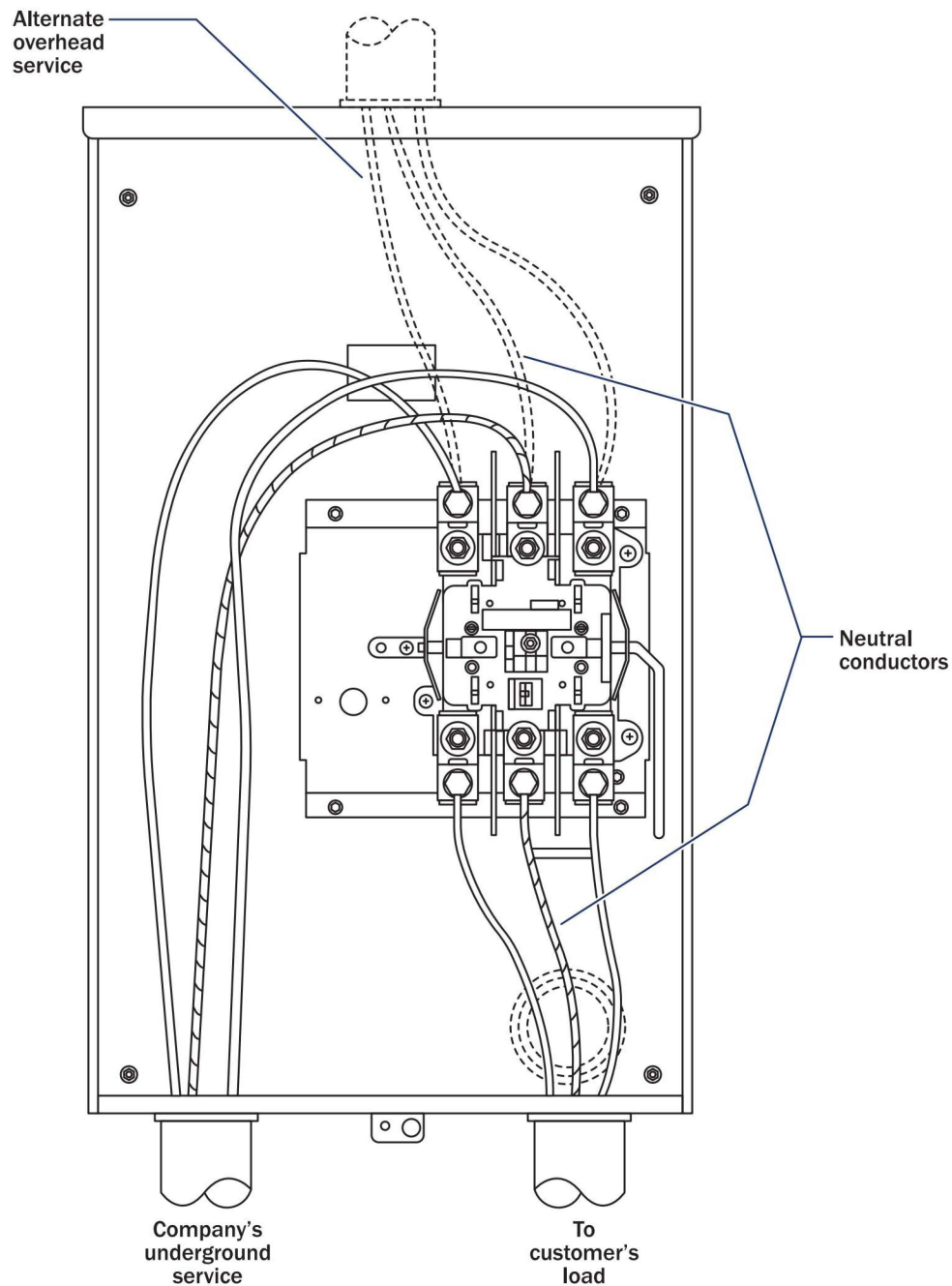

**Intermittent Duty - 400 Amp
Continuous Duty - 320 Amp**

FIGURE 26 Wiring Diagram for Single-Phase, 3-Wire, 400 Amp, Self-Contained Meter Socket

Notes

1. This meter socket is for use on the following service: 400 ampere, 3-wire, single-phase, 120/240 volts.
2. Terminations are designed for one or two conductors per phase.
 - a. Single conductor per phase: (1) #4-600 MCM CU-AL

b. Two conductors per phase: (2) 1/0-250 MCM CU-AL

Wiring Diagram for Horizontal Grouped Meter Installations Single-Phase, 3-Wire, Two Position Self Contained Metering

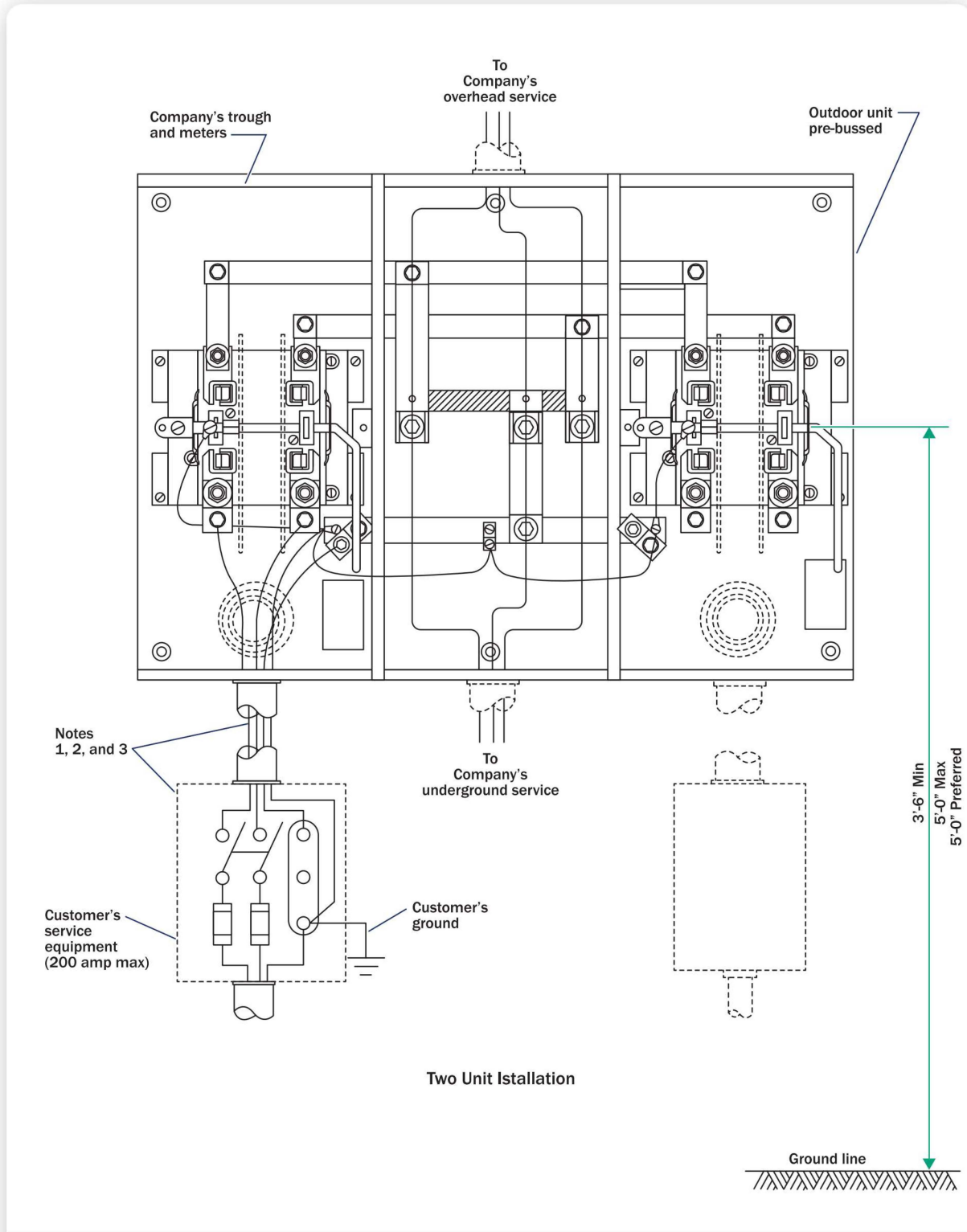

FIGURE 27 Wiring Diagram for Horizontal Grouped Meter Installations Single-Phase, 3-Wire, Two Position Self Contained Metering

Notes

Printed on: 04/07/2022 | This version is only valid if the revision date matches the online version.

1. All customer load conductors shall exit the bottom of the meter socket immediately below the associated meter. The trough shall not be used as a raceway.
2. Each customer's service equipment must contain main disconnecting means.
3. Each meter service equipment shall be permanently and plainly marked to identify the exact portion of the building served.
4. Customers service equipment (200 amp max)

Polyphase Self-Contained Meter Installations From Overhead Distribution

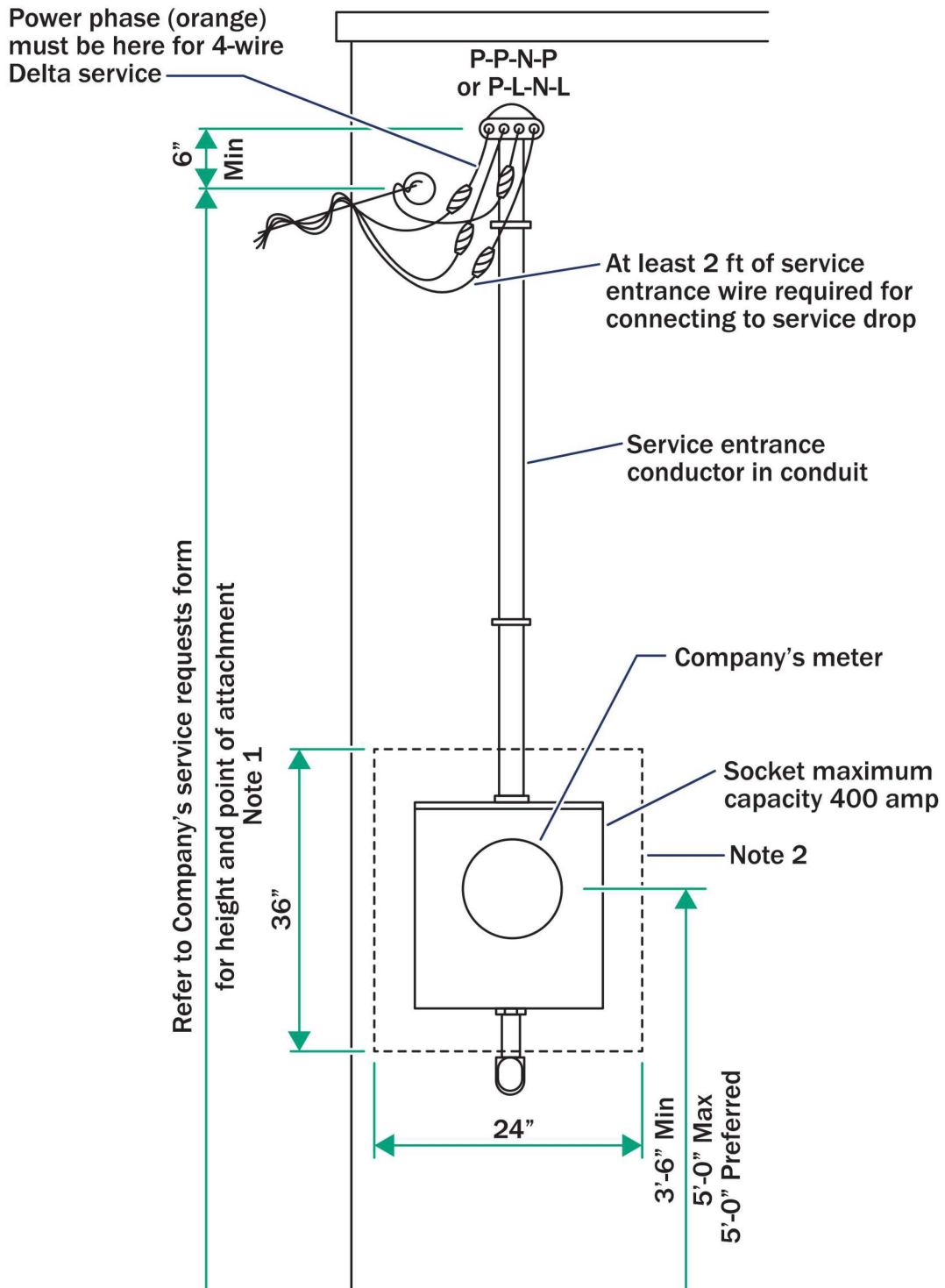

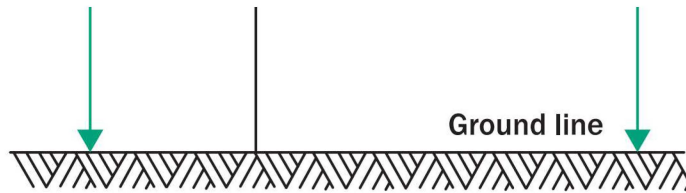

FIGURE 28 Polyphase Self-Contained Meter Installations From Overhead Distribution

Notes

1. Minimum heights for areas not subject to truck traffic are:
12'-0" for 120/208 and 120/240 volt services and
15'-0" for 480 volt power service.
Other heights may be required depending on local conditions.
2. Dotted line around meter trough is the minimum clear space around meter or size of meter board.
3. Power phase (orange) must be here for 4-wire Delta service
4. At least 2 feet of service entrance wire required at weather head for connecting to service drop.

Wiring Diagram for Three-Phase, 4-Wire 200 Amp, Self-Contained Meter Socket

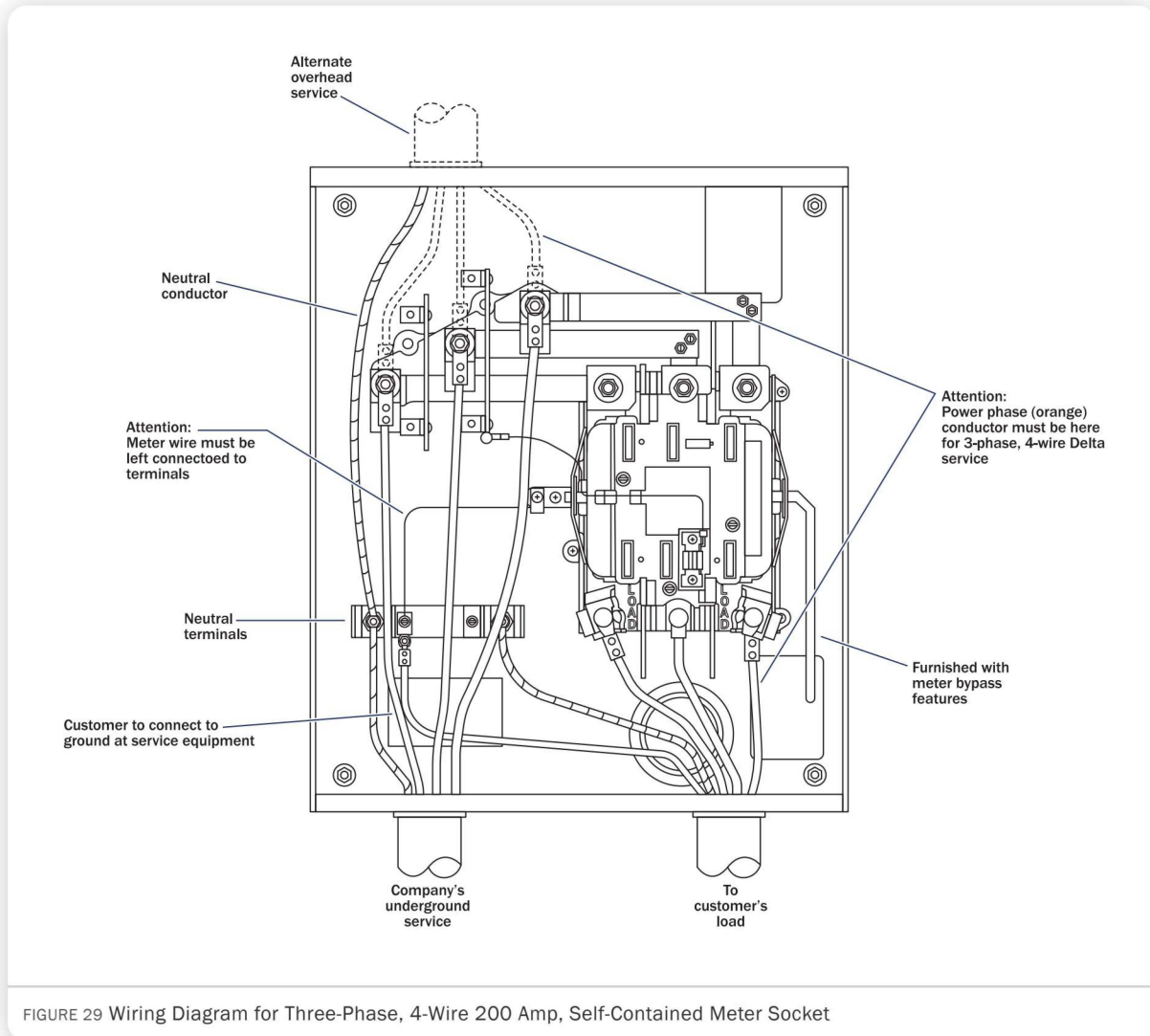
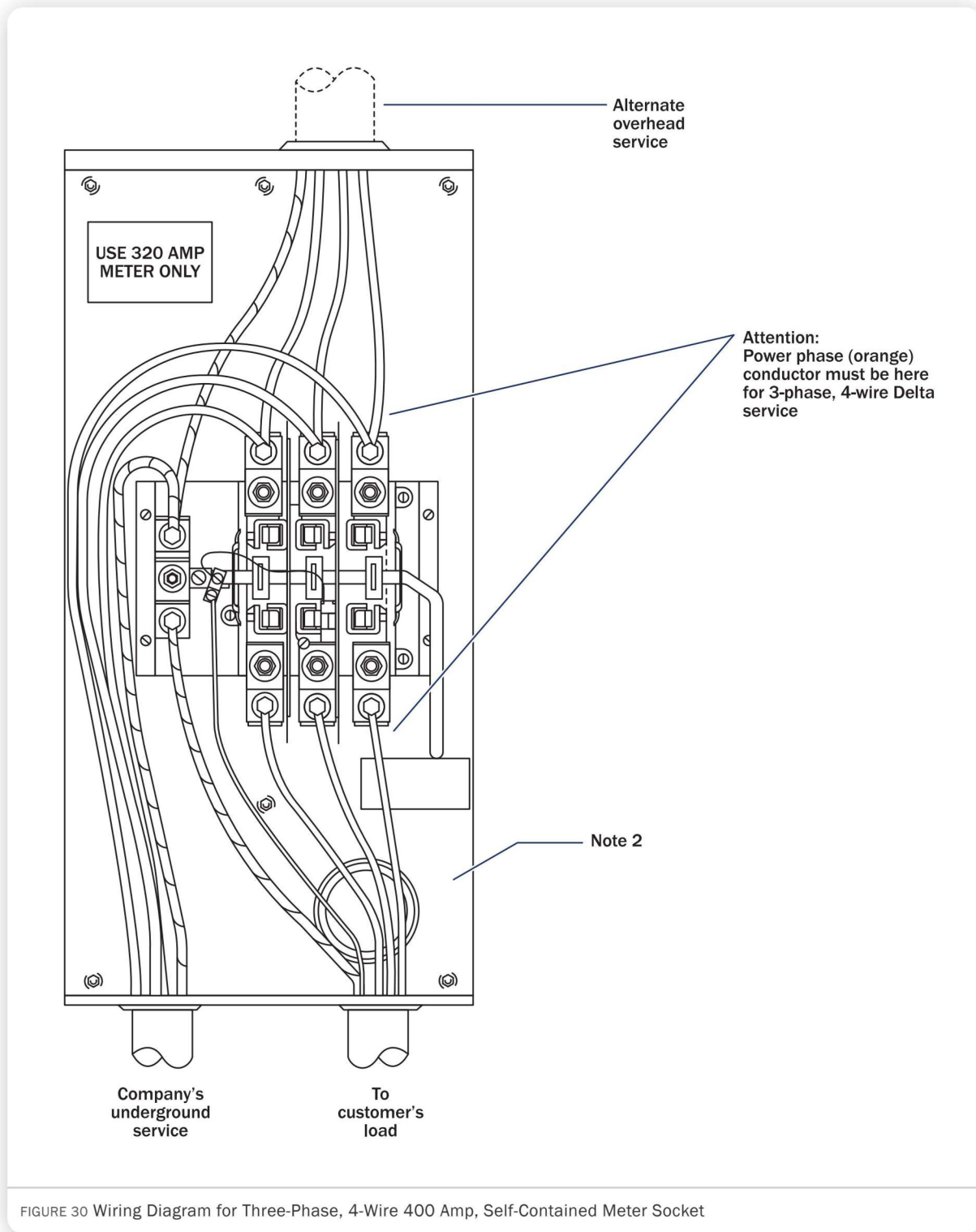

FIGURE 29 Wiring Diagram for Three-Phase, 4-Wire 200 Amp, Self-Contained Meter Socket

Notes

1. This meter socket is for use on the following services:
 - a. 4-wire, 3-phase Delta, 120/240 volts,
 - b. 4-wire, 3-phase wye, 120/208 and 277/480 volts.
2. Terminations are designed for only one conductor per phase.
3. Attention: Power phase (orange) conductor must be terminated at "C" phase for 3-phase, 4-wire Delta service.
4. Customer to connect to ground at service equipment. Customer must install a complete ground in accordance with National Electrical Code and local inspectors.
Customer must not route grounding conductor (from disconnect to ground rod) through meter socket.

Wiring Diagram for Three-Phase, 4-Wire 400 Amp, Self-Contained Meter Socket



Notes

1. This meter socket is for use on the following services:
 - a. 4-wire, 3-phase Delta, 120/240 volts
 - b. 4-wire, 3-phase Wye, 120/208 and 277/480 volts.
2. Terminations are designed for one or two conductors per phase.
 - a. Single conductor per phase: (1) #4-600 MCM CU-AL
 - b. Two conductors per phase: (2) 1/0-250 MCM CU-AL

Printed on: 04/07/2022 | This version is only valid if the revision date matches the online version.

3. Attention: Power phase (orange) conductor must be terminated at "C" phase for 3-phase, 4-wire Delta service.

Wiring Diagram for Horizontal Grouped Meter Installations Three-Phase, 4 Wire, Two Position Self-Contained Metering

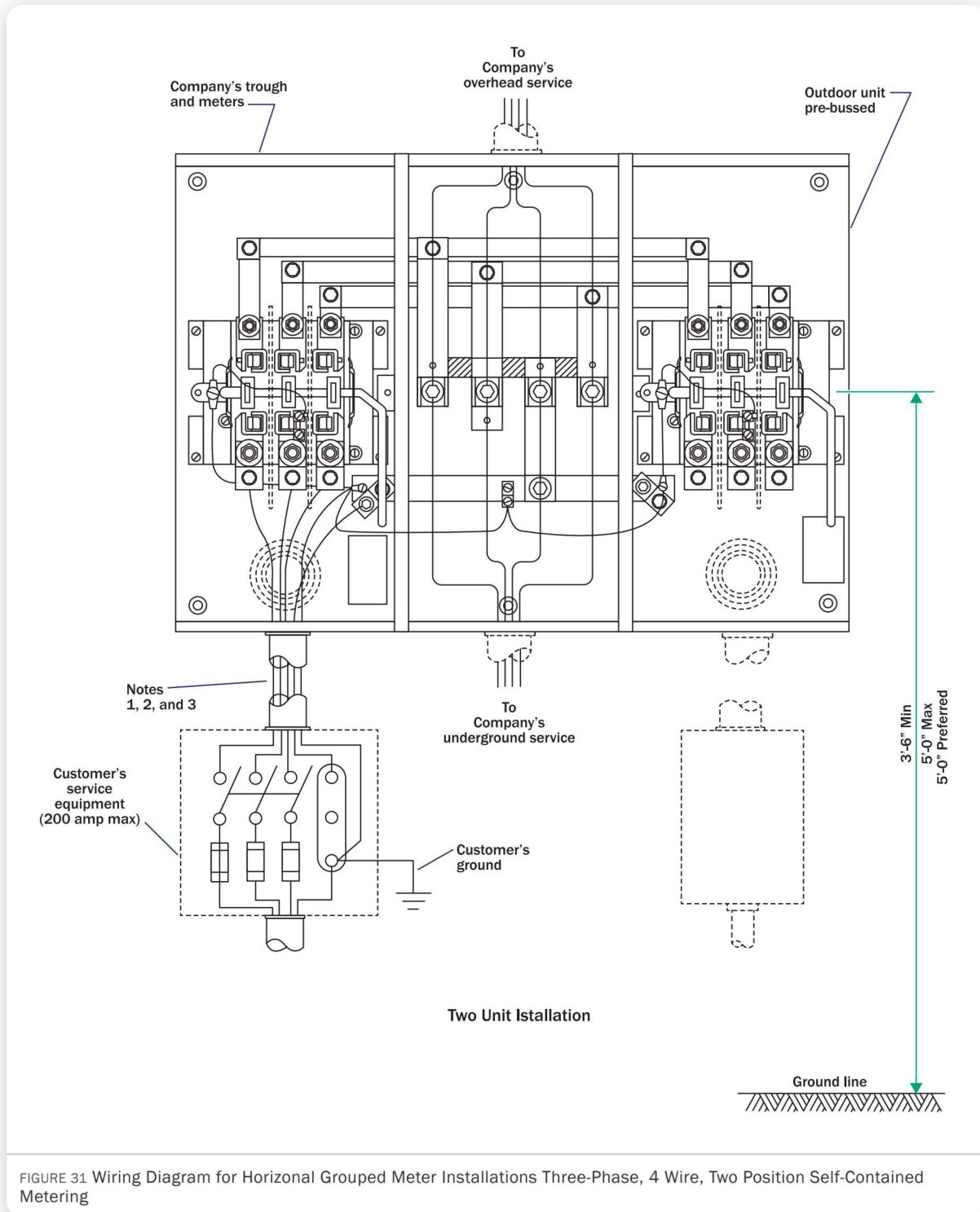

FIGURE 31 Wiring Diagram for Horizontal Grouped Meter Installations Three-Phase, 4 Wire, Two Position Self-Contained Metering

Notes

1. All customer load conductors shall exit the bottom of the meter socket immediately below the associated meter. The trough shall not be used as a raceway.
2. Each customer's service equipment must contain main disconnecting means.

3. Each meter and service equipment shall be plainly marked to identify the exact portion of the building served.
4. Customer's service equipment (200 amp max).
5. Customer must install a complete ground in accordance with National Electrical Code and local inspectors. Customer must not route grounding conductor (from disconnect to ground rod) through meter socket.

Modular Grouped Meter Installations - Underground Service Meter Sockets with Individual Breakers Furnished by Customer

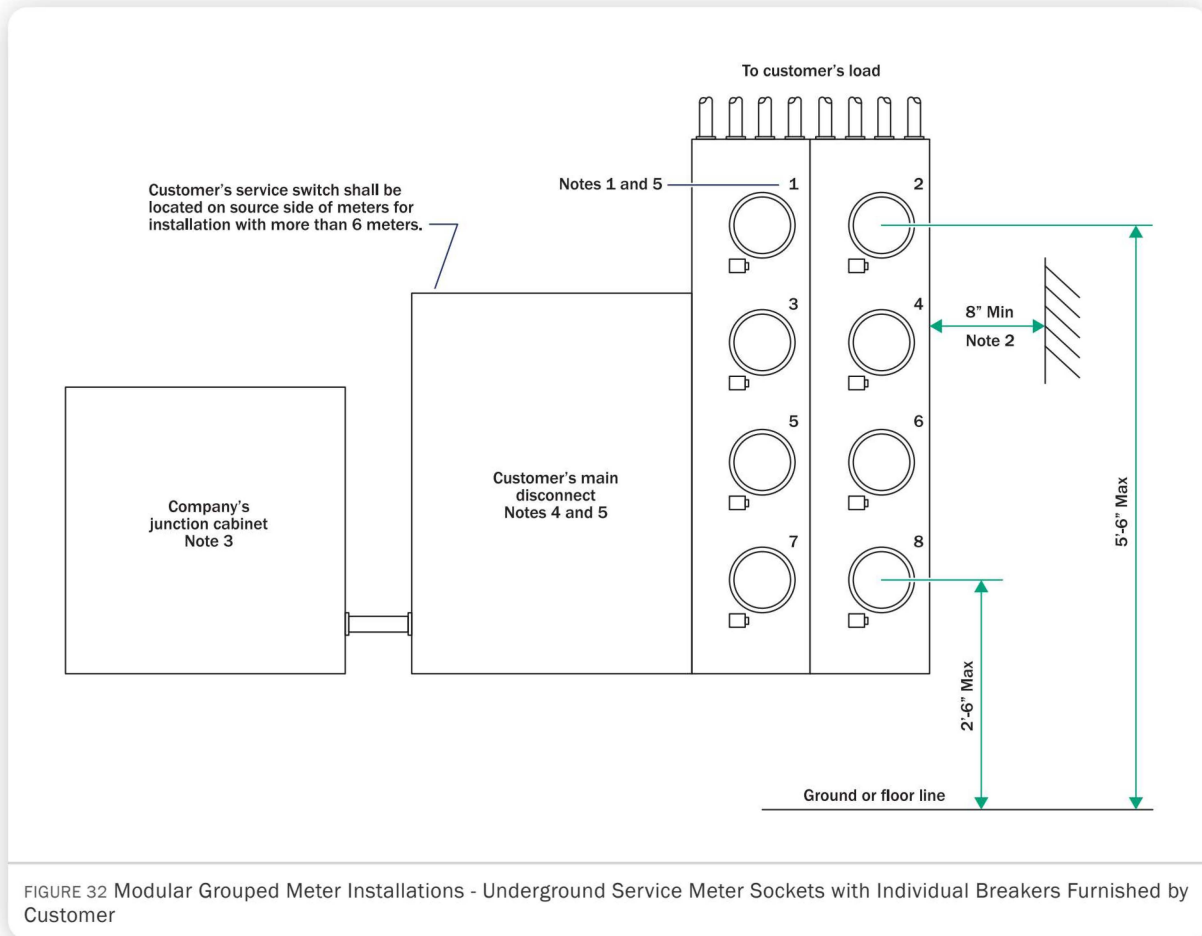

Notes

1. Each meter and service equipment shall be permanently and plainly marked by the contractor to identify' the exact portion of the building served.
2. Maintain a 4 foot readily accessible space in front of the meter. **DO NOT** locate meter within 8" of a right-angle construction.
3. Junction cabinet not required when service switch is designed with a utility pull box section.
4. A main disconnect ahead of the meters is required for installations with more than 6 meters.
5. Only modular meter sockets and equipment approved by Consumers Energy are to be installed. Refer to the Consumers Energy web site [Customer Owned Meter Sockets & Metering Equipment](#).
6. Customer's service switch shall be located on source side of meters for installation with more than 6 meters.

Wiring Diagram for Modular Grouped Meter Installations - Underground Service Meter Sockets with Individual Breakers Furnished by Customer

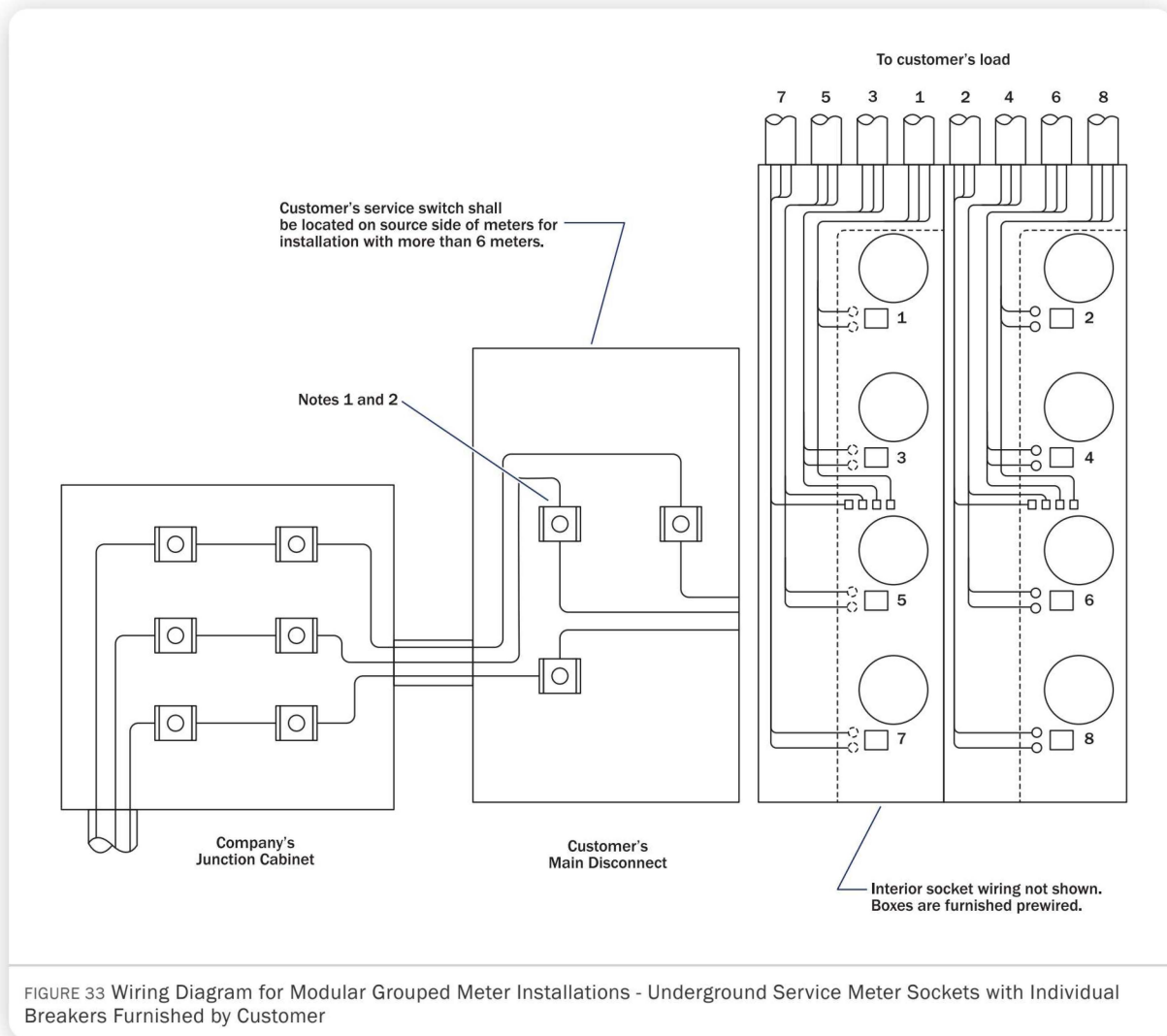

Notes

1. Position of neutral bus varies according to manufacturer.
2. Similar equipment is available with four bus, five terminal meter sockets for 120/208V network services, and seven terminal meter sockets for 120/208V, 4W wye and 120/240V, 4W delta, 3-phase services.
3. Customer's service switch shall be located on source side of meters for installation with more than 6 meters
4. Interior socket wiring not shown. Boxes are furnished prewired.
5. Each meter and service equipment shall be permanently and plainly marked by the contractor to identify' the exact portion of the building served.
6. Maintain a 4 foot readily accessible space in front of the meter. **DO NOT** locate meter within 8" of a right-angle construction.
7. Junction cabinet not required when service switch is designed with a utility pull box section.
8. Only modular meter sockets and equipment approved by Consumers Energy are to be installed. Refer to the Consumers Energy web site [Customer Owned Meter Sockets & Metering Equipment](#).

Transformer Rated Single and Polyphase Meter Installation Bar Type CTs

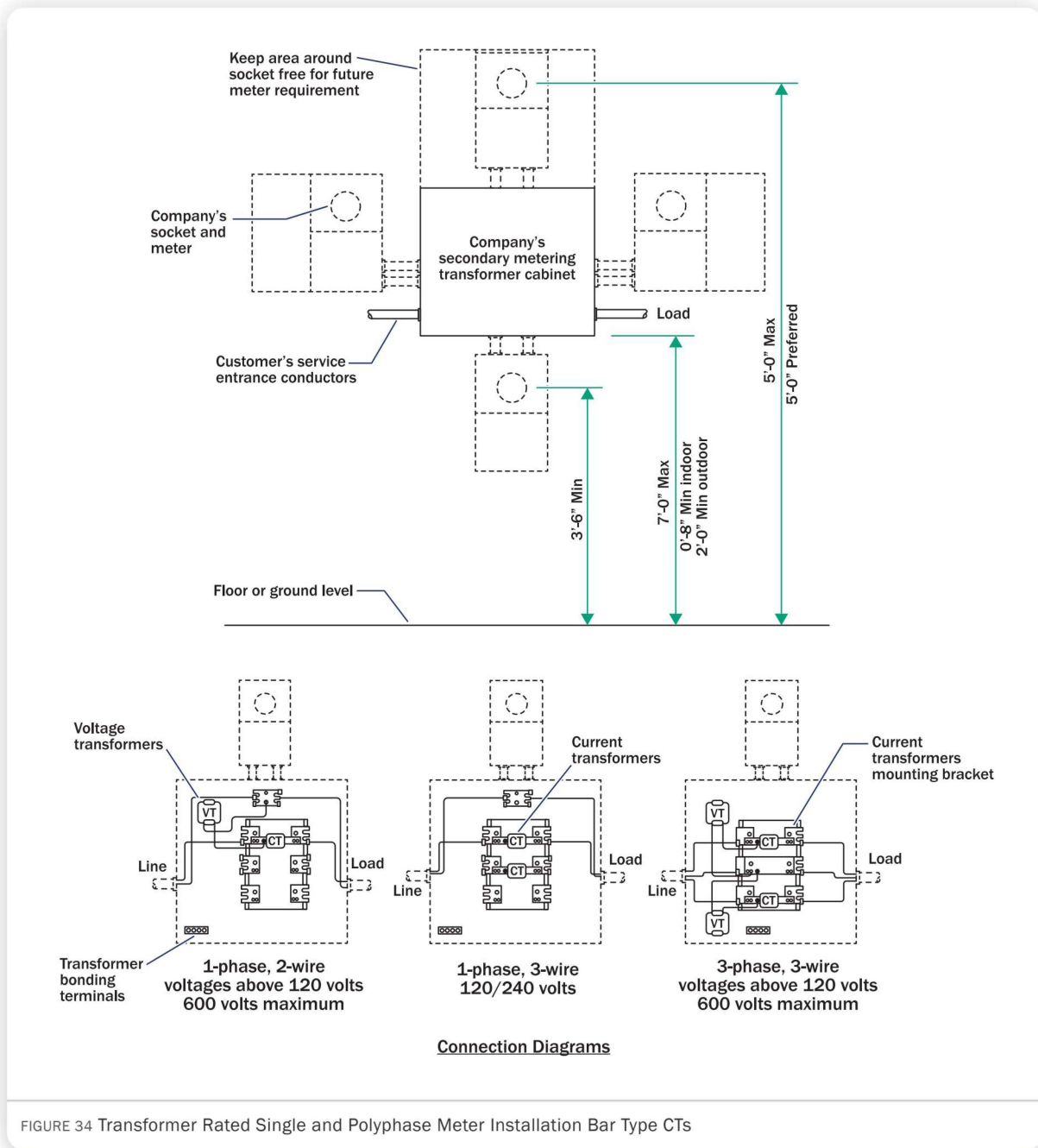

FIGURE 34 Transformer Rated Single and Polyphase Meter Installation Bar Type CTs

Notes

1. The service switch should be located on the load side of the meter unless local rules or ordinances specify otherwise.
2. Only primary wiring is shown.
3. Keep area around meter socket free for future meter requirement
4. All neutrals shall be terminated at the provided neutral mounting block.

Transformer Rated Polyphase Meter Installation Bar Type CT's

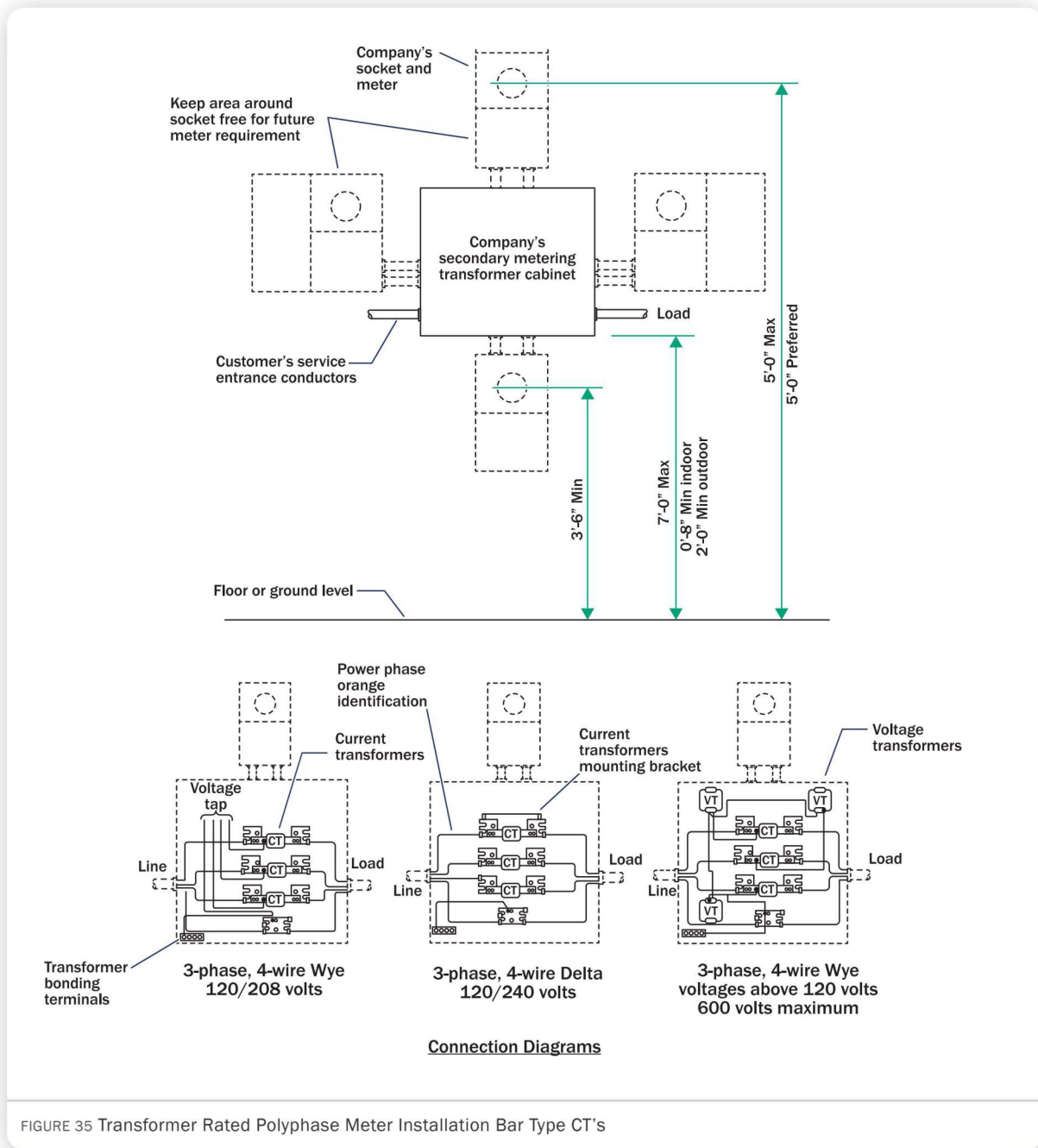
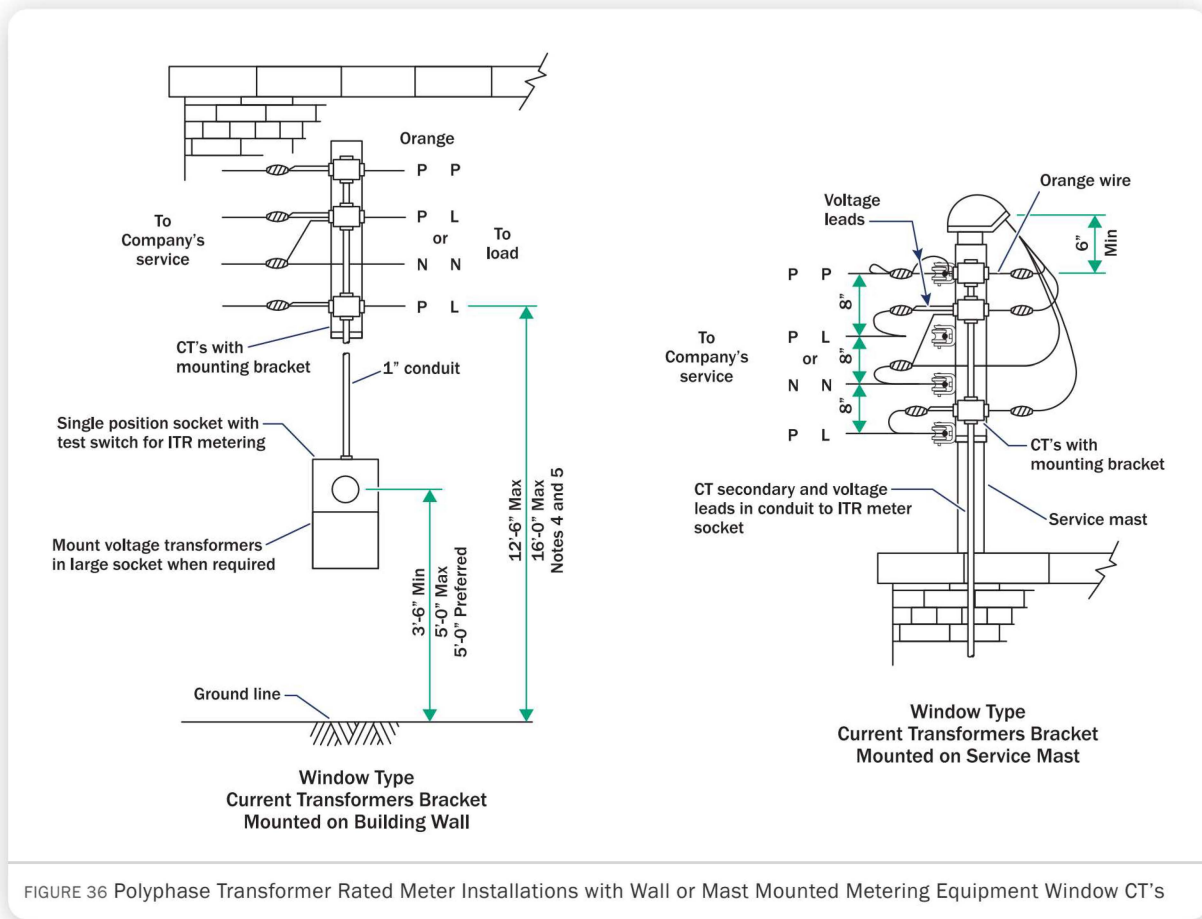

FIGURE 35 Transformer Rated Polyphase Meter Installation Bar Type CT's

Notes

1. The service switch be located on the load side of the meter unless local rules or ordinances specify otherwise.
2. Only primary wiring is shown.
3. Keep area around socket free for future meter requirement
4. Power phase of a 120/240 3 phase 4 wire system shall be marked orange and terminated at the top position of the current transformer rack.
5. All neutrals to be terminated at the neutral mounting block.

Polyphase Transformer Rated Meter Installations with Wall or Mast Mounted Metering Equipment Window CT's



Notes

1. The customer will furnish and install all service wiring shown, wiring supports and conduits for the ITR socket wiring and will install the meter sockets furnished by Company.
2. The Company will furnish and install the meter, the ITR socket and meter wiring.
3. The load and conductor size will determine the type of installation to use.
4. The normal height for three-phase, 480 volt Delta power is 15 feet. Normal height subject to change by the Company.
5. Company approval required for mounting height greater than 16 feet.
6. Mount voltage transformers in large socket when required.

Wiring Diagram for Padmount Metering 600 Volts and Below

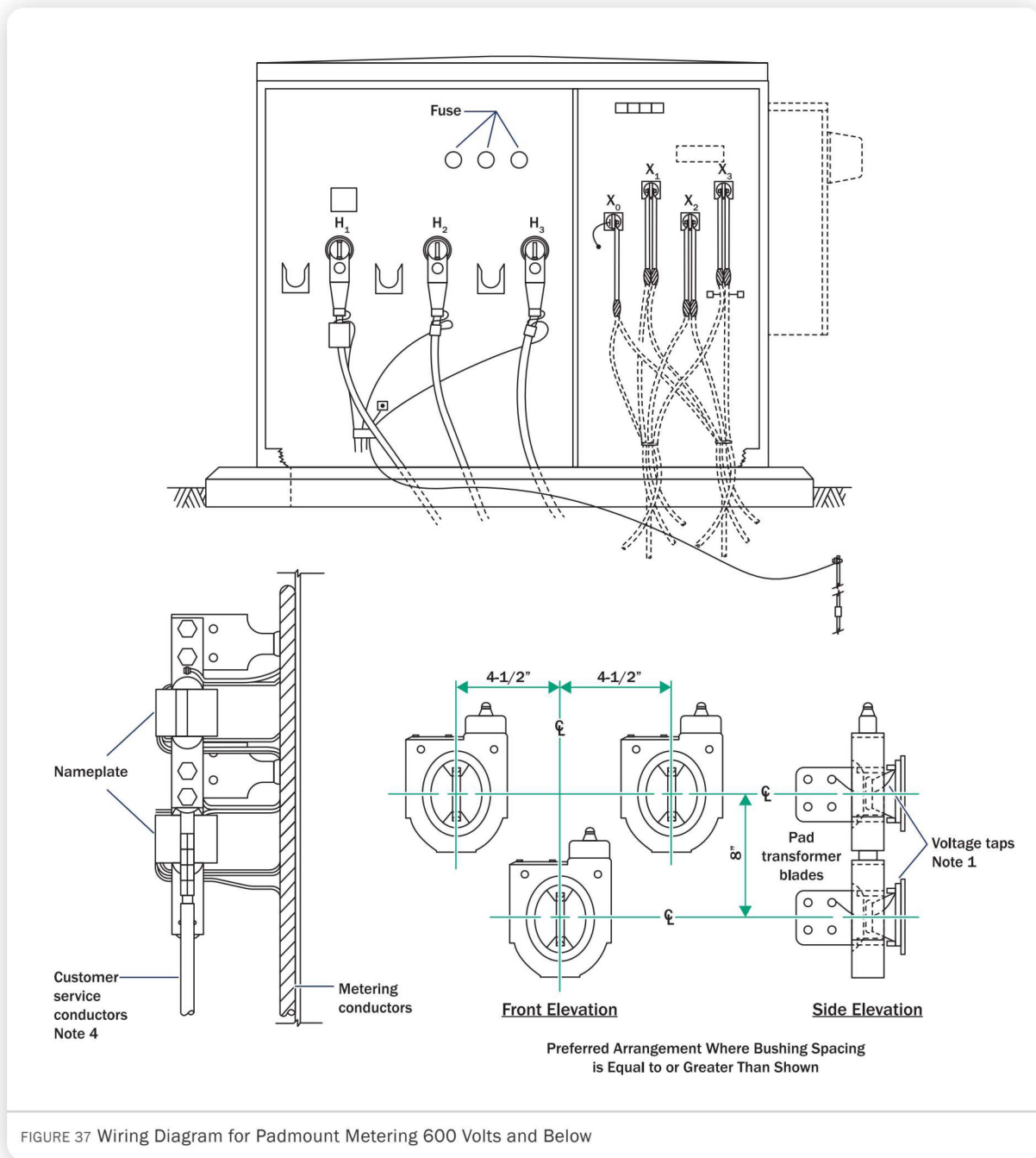

Notes

1. Voltage taps shall be made to each phase under an additional unit nut on one mounting bolt of the service connector. Voltage leads must pass thru the CT window.
2. Application limitations:
(1) one service per installation.
3. Installation may also apply to single-phase.
4. Maximum of four parallel conductors per phase or terminal with a maximum conductor size of 600 kcmil.

Service Switch for Use with Customer's Portable Generator Unit

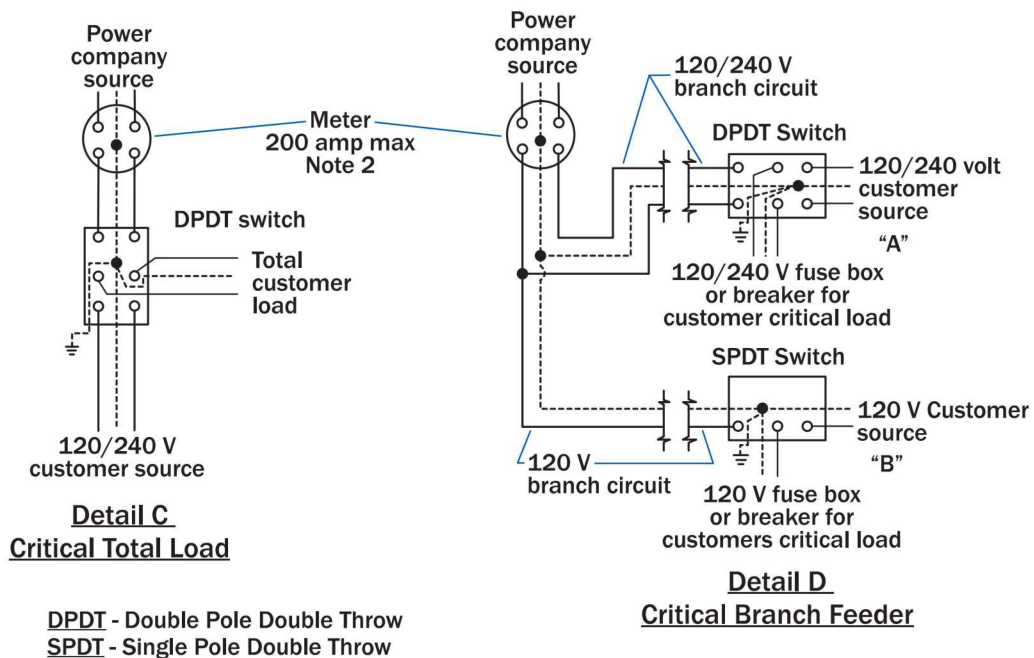
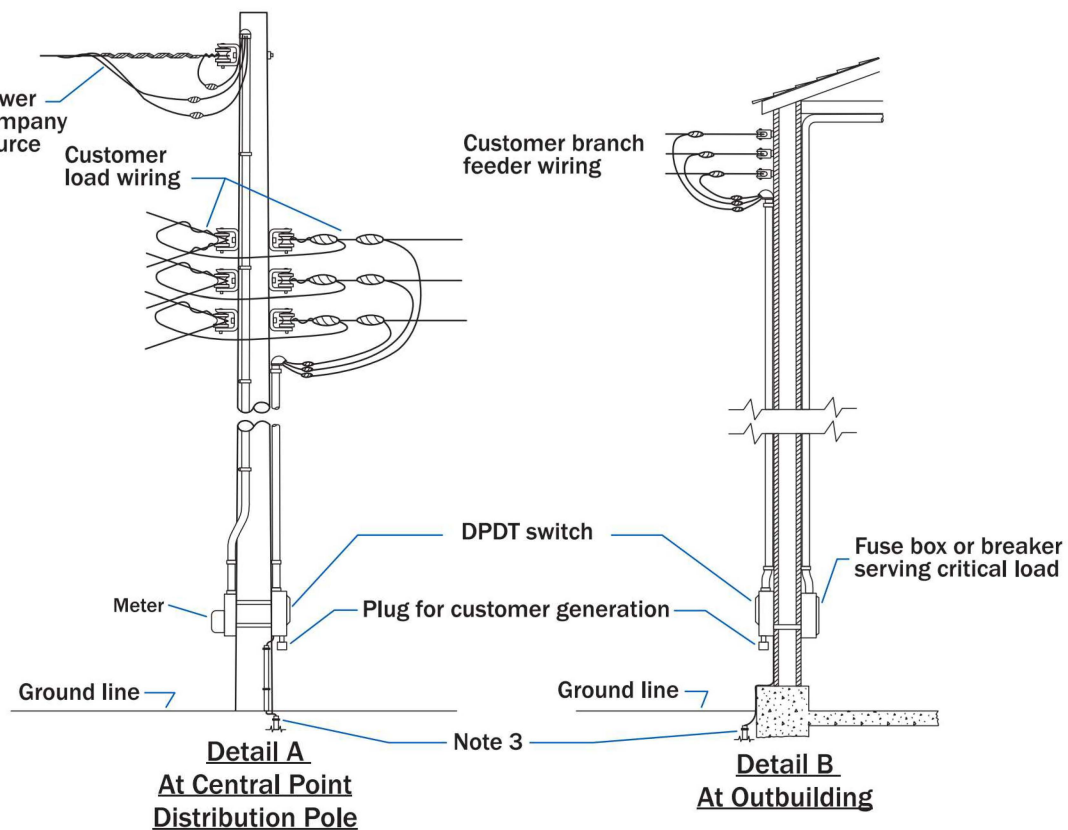

FIGURE 38 Service Switch for Use with Customer's Portable Generator Unit

Notes

1. Customer's wiring and equipment must meet all local and state regulatory requirements.

Printed on: 04/07/2022 | This version is only valid if the revision date matches the online version.

2. All required permits must be obtained (i.e. county, township, city, etc.).
3. The system must pass the electrical inspection.
4. The generator must be electrically isolated from Consumers Energy's system by either:
 - a. A transfer switch or similarly approved isolation switch, which must be installed to isolate the generator from Consumers Energy's system. Customers must purchase these from distributors. A list of approved model numbers is located on the Company's website under ["Customer Purchased Meter Sockets—Approved List"](#).
 - b. Or when equipment and/or appliances are directly connected to the generator using flexible extension cords with current ratings adequate for the equipment and/or appliances being served.
5. The customer must never pull their electric meter to disconnect from Consumers Energy's system.
6. Detail A shows the recommended typical physical arrangement for the customer's critical total load switching on a central point distribution pole. Detail B shows a similar arrangement for a branch feeder to a critical load at an outbuilding.

Wiring Diagram for Service Switch Used with Customer's Portable Generator Unit

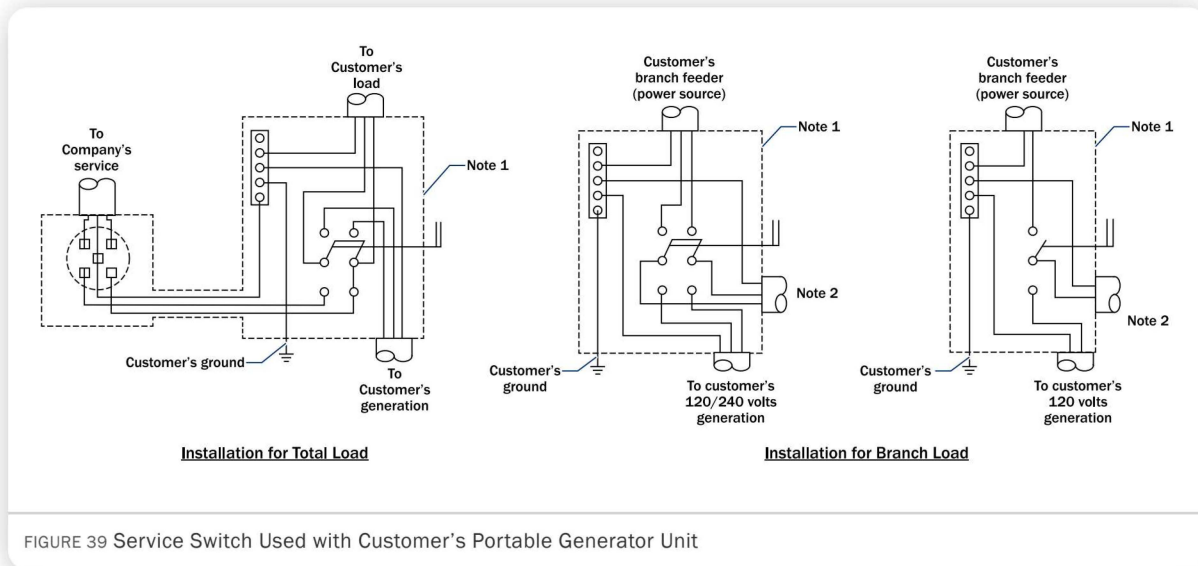

Notes

1. Customer's double-pole, double-throw switch.
2. To customer's fuse box or breaker for critical load

Wiring Diagram for Single-Phase, 3-Wire combinations Meter Socket and Transfer Switch

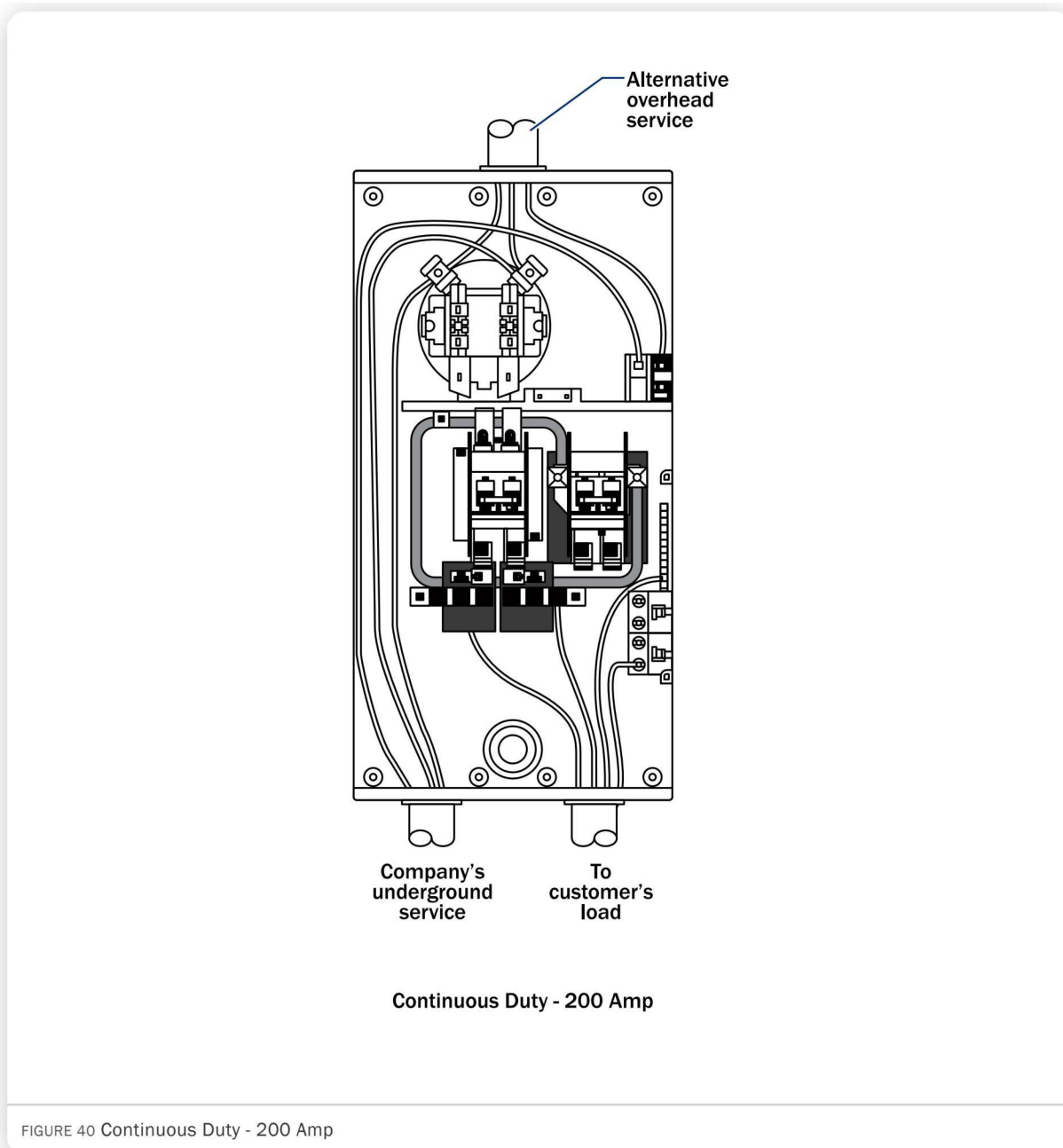

Notes

1. The meter socket must meet Consumers Energy qualification and be pre-approved before installation.
2. Line side is designed for single conductor and load is designed for multiple conductors.

Underground Services Communications Pedestal Service Metered

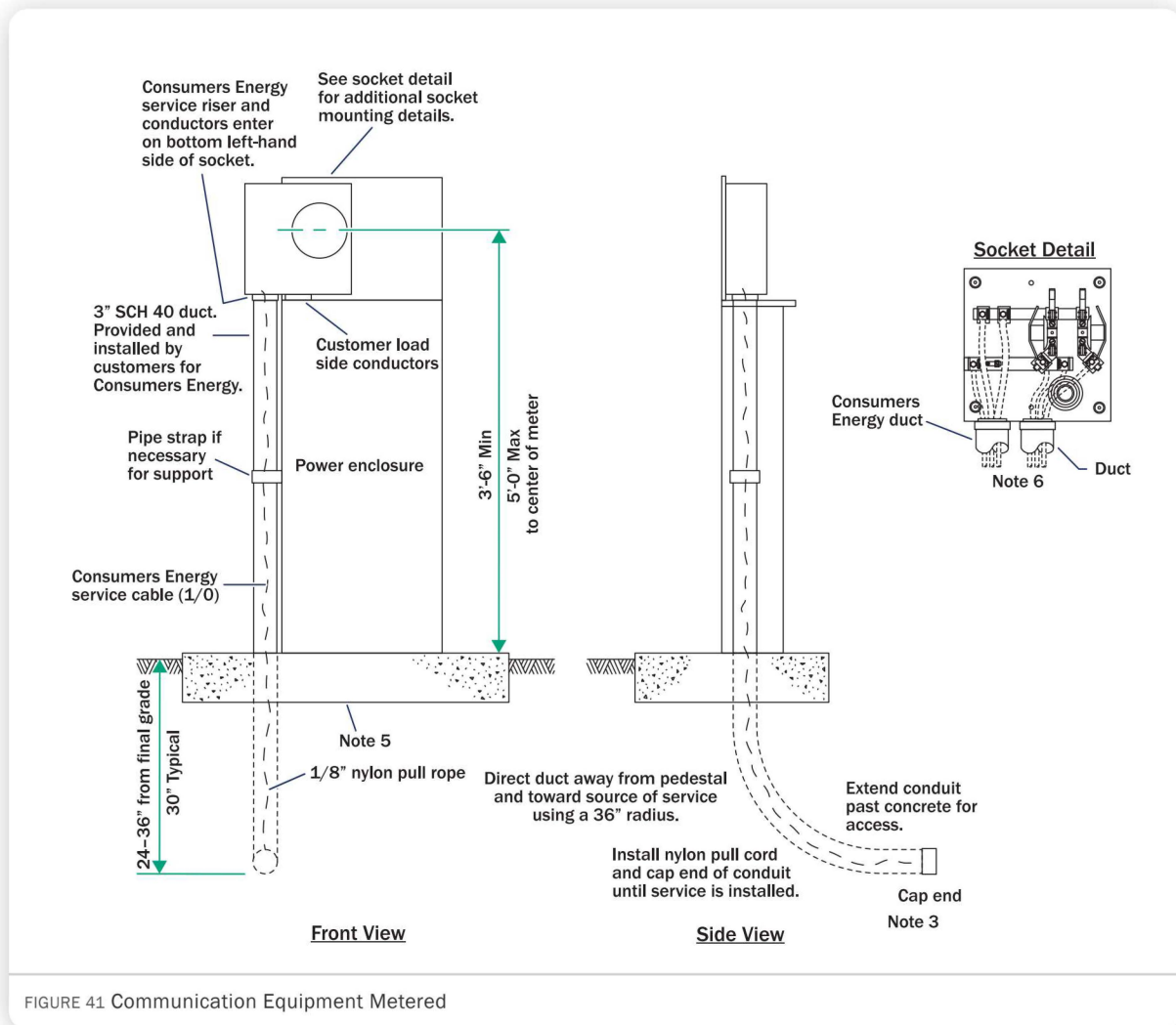

Notes

1. Metering only required if justified by load. Not all communication pedestals must be metered.
2. Cable to the sources may be direct buried it be - after it - from pedestal areas depending on supplications needs.
3. Consumers Energy service riser and conductors under buttons on left-hand side of socket.
4. Socket provided by Consumers Energy and installed be customer.
5. Pedestal and pad (customer owned and installed) not to be located over electric or gas trench.
6. Refer to Socket Details for additional socket mounting details.

Underground Services Communications Pedestal Unmetered

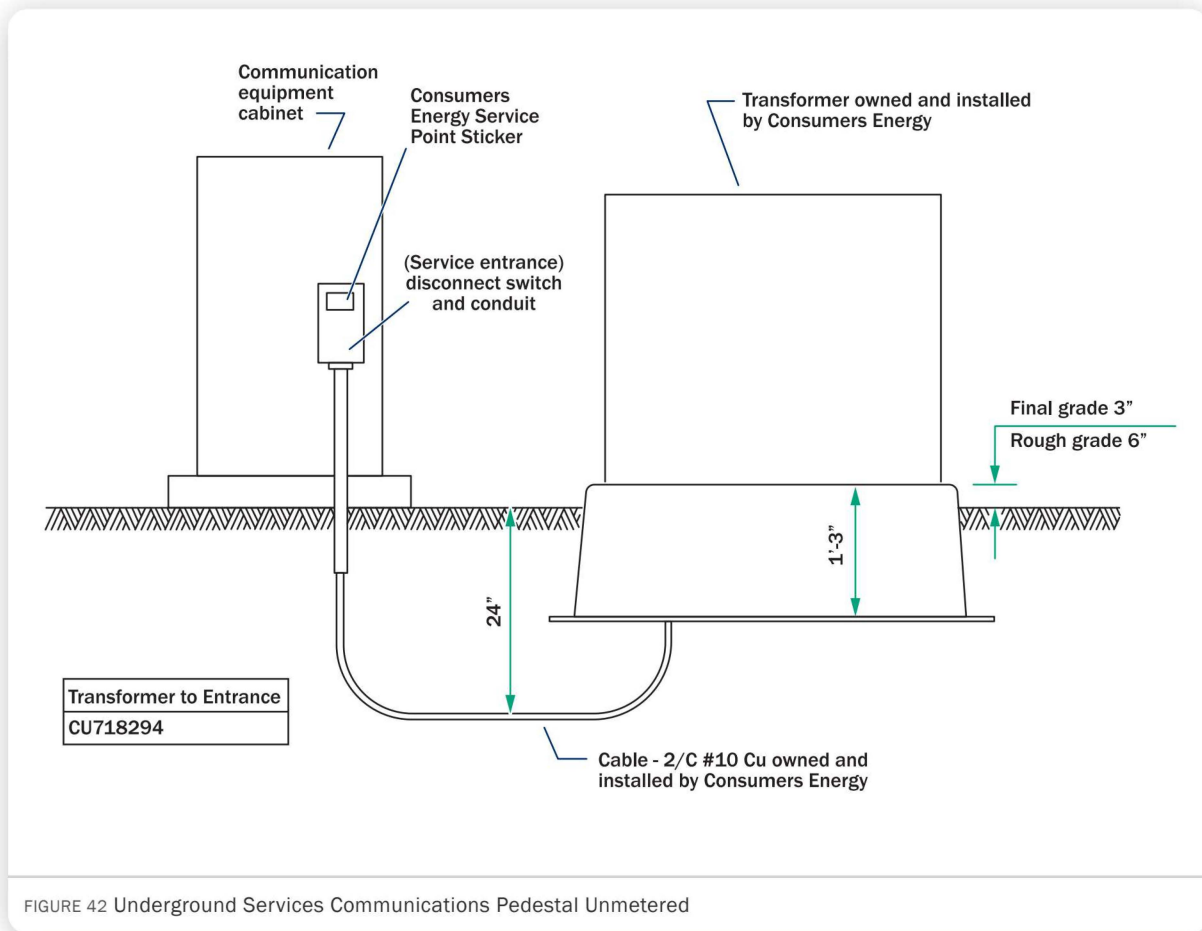

Notes

1. All material and equipment is owned and installed by the customer except as noted.
2. Service connection and disconnection is to be made by Consumers Energy.

Underground Services Communications Pedestal Unmetered

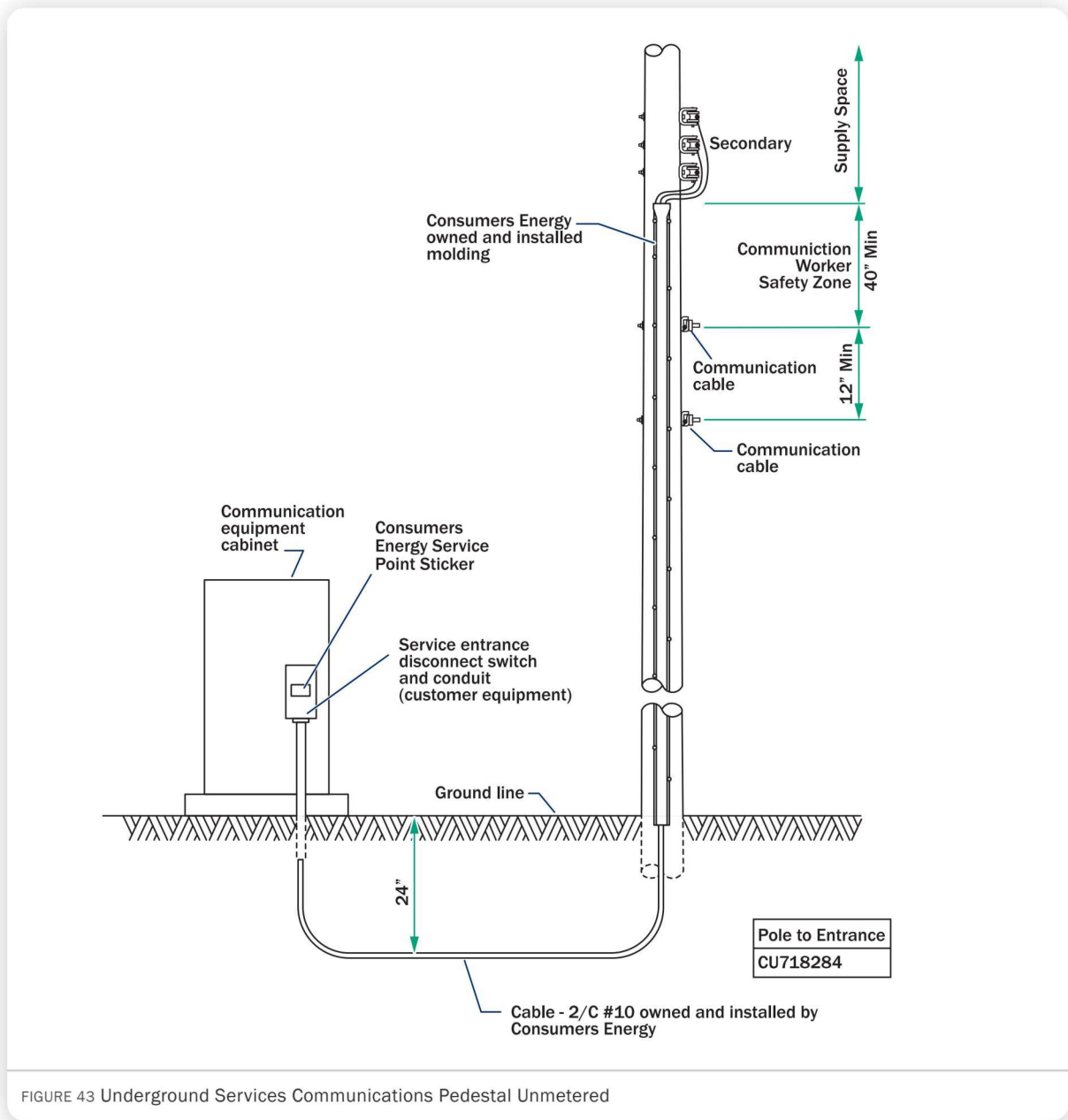

FIGURE 43 Underground Services Communications Pedestal Unmetered

Notes

1. All material and equipment are owned and installed by the customer except as noted.
2. Service connection and disconnection is to be made by Consumers Energy.

Underground Services Communications Pedestal Alternate

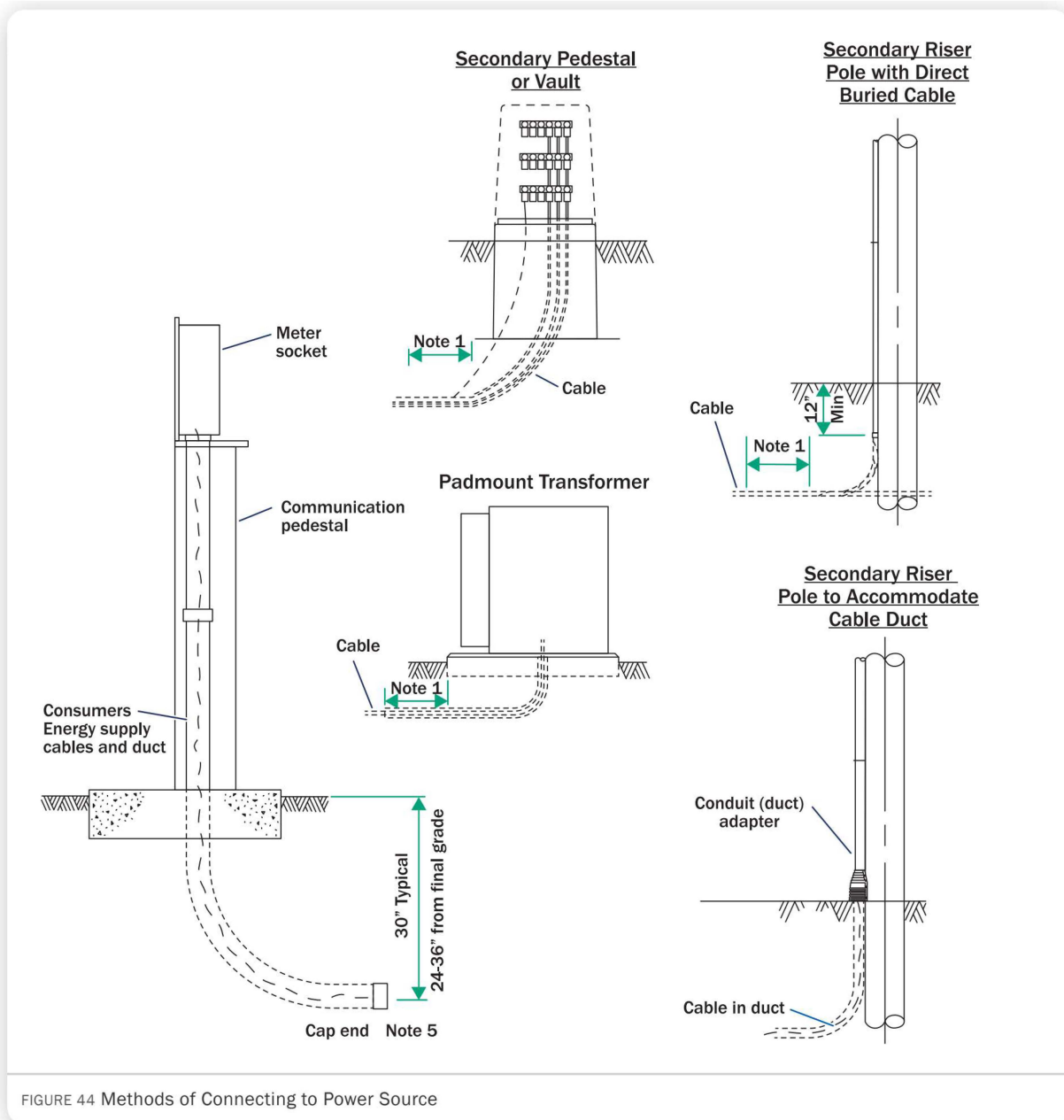

FIGURE 44 Methods of Connecting to Power Source

Notes

1. If duct is used, stop it a minimum of 12" from pedestal, transformers or pole.
2. Cable may be directly buried or in duct after it leaves the pedestal area depending upon application needs.

Communication Towers, Customer Metering and Addressing

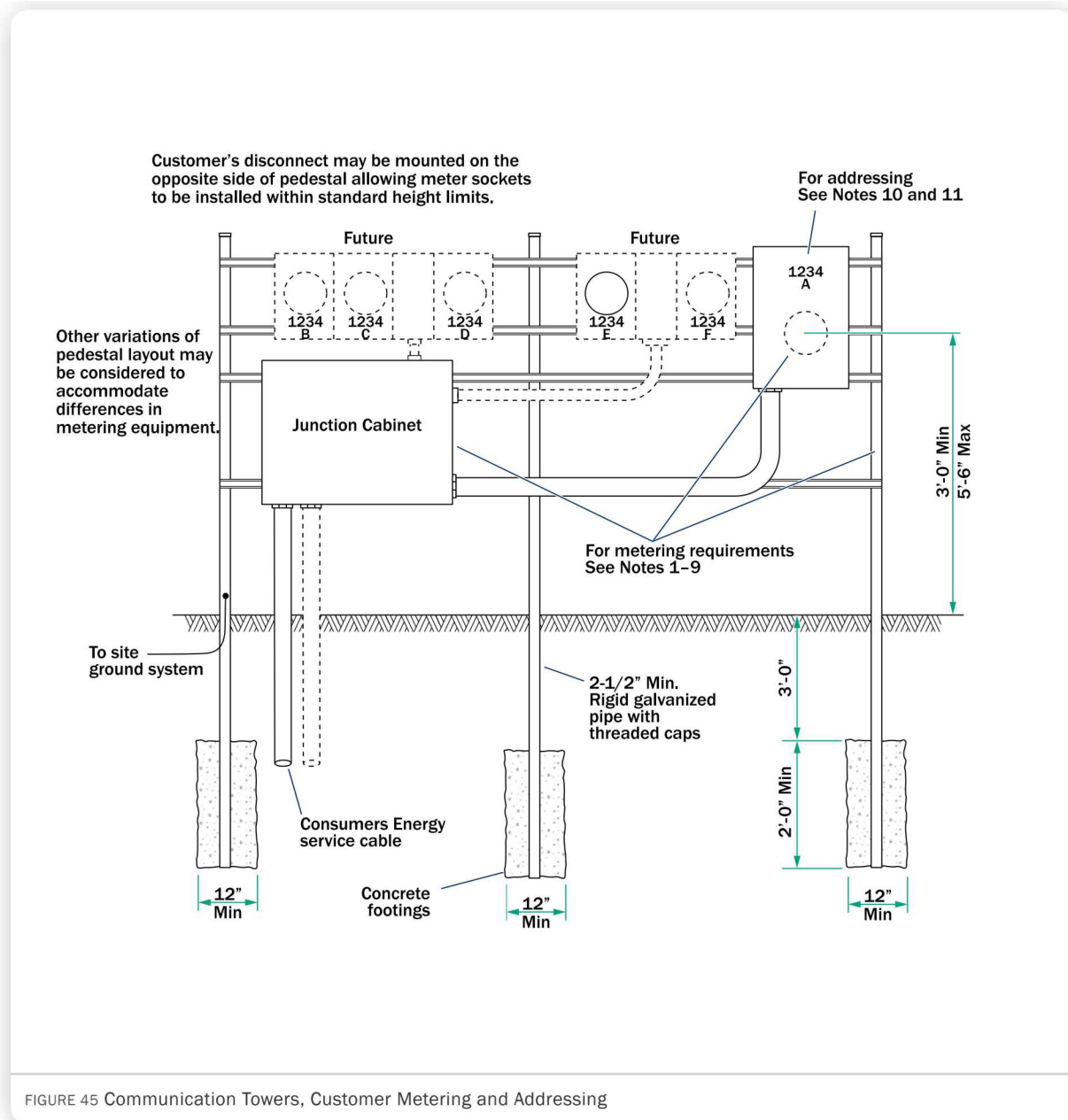

FIGURE 45 Communication Towers, Customer Metering and Addressing

Notes

- Customer is to provide and install metering equipment on the Unistrut pedestal support
- To ensure that the equipment is readily accessible for safe operation and maintenance, the customer will install the metering equipment and pedestal to meet the minimum clearance requirements in the National Electrical Code (NEC), unless Consumers Energy requires a greater clearance. Typical clearance requirements include:
 - Three feet minimum around the metering pedestal.
 - Five feet minimum in front of the metering equipment.
- The customer must inform Consumers Energy specifically which meter(s) need(s) to be set for the initial request.
- Each carrier requires a meter to obtain service.
- Consumers Energy will furnish a junction cabinet as a point of service when the customer installs more than one meter socket or multi-position socket (i.e. gang sockets, Meter Pak, or modular metering).
- Depending on the number of carriers, the customer may have to purchase Consumers Energy approved multi-position meter sockets in order to comply with the junction cabinet's limitations.
- Individual meter sockets may be fed from a customer provided square duct installed directly above the sockets.

8. Customers must provide an address except in areas where Consumers Energy is responsible for assigning them.
9. The customer must identify addressing on the meter sockets. It is recommended that the first meter installed is labeled with the address followed by an A and subsequent sockets would be addressed B, C, etc. It is not acceptable to identify meter sockets with only the communication carrier's name.
10. Customer is to bond the meter support pedestal to the site ground system to maintain a common electrical potential.

Customer Site Requirements

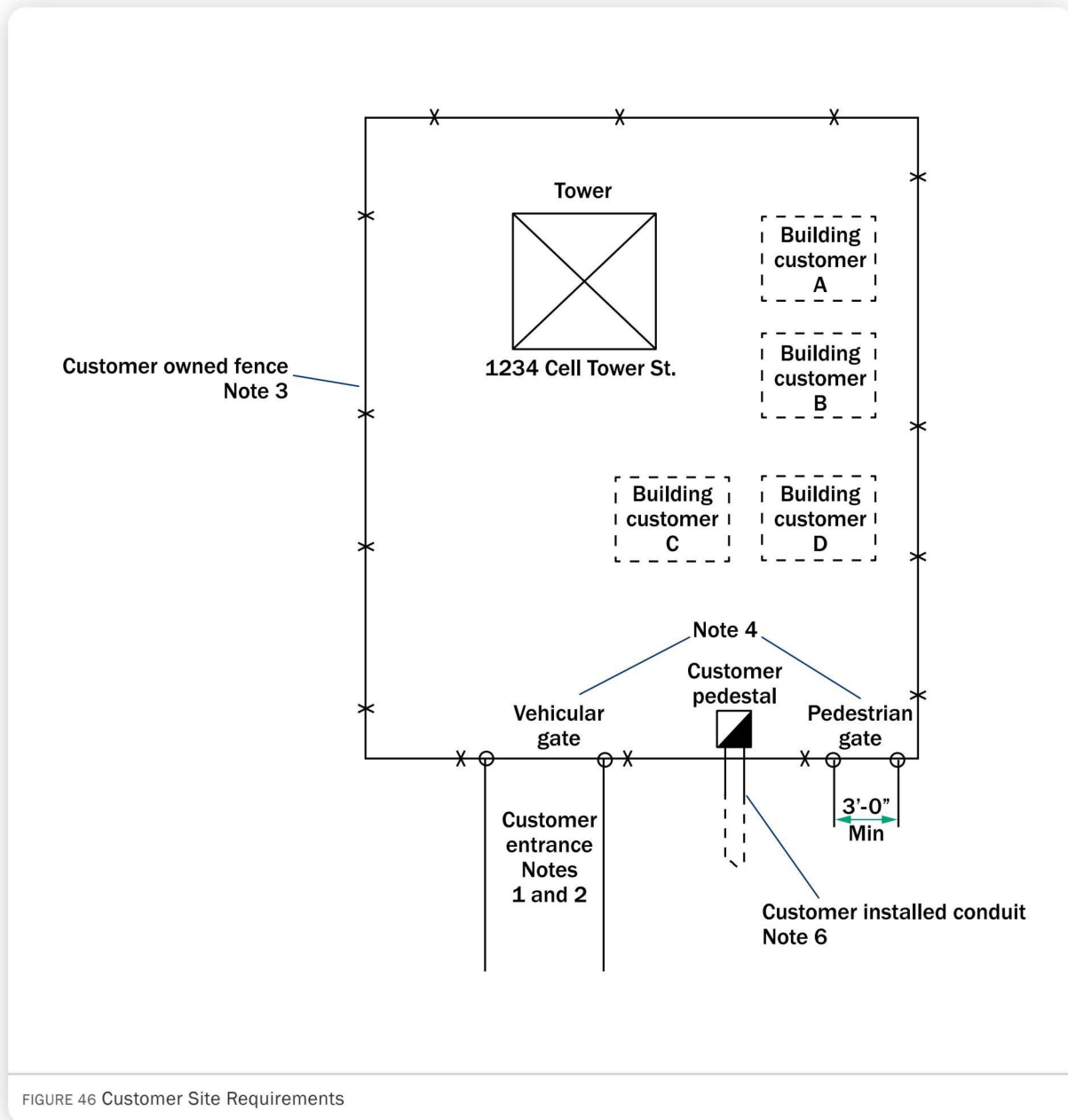

FIGURE 46 Customer Site Requirements

Notes

1. Consumers Energy must be able to access the site at all times. If the driveway or road has a gate, provisions must be made in order for Consumers Energy to have access to the site.
2. During winter months, the customer will be required to provide snow removal for meter reading, maintenance, or any other work that may need to be performed.
3. The customer will not be allowed to enclose or install any fencing around Consumers Energy distribution equipment (i.e. poles, transformers, secondary vaults, or enclosures).
4. A readily accessible pedestrian gate that is dedicated to Consumers Energy.

Printed on: 04/07/2022 | This version is only valid if the revision date matches the online version.

5. A readily accessible vehicular gate.
6. Provisions shall be made for Consumers Energy locking mechanisms for securing the dedicated pedestrian gate and the vehicular gate.
7. Customer must install service conduit inside the fenced area to an approved point outside of the fenced area. Conduit credit will only apply if installed the entire length of the service. At no time will Consumers Energy install conduit or trench inside the fenced area.
8. Consumers Energy reserves the right to deny or shut off services for failure to provide access.
9. Customer is to install SCH 40 PVC gray electrical conduit, UL listed. It must extend at least five feet from the customer owned fence.